

# R5 Conveyor User Manual

# Directory / Verzeichnis / Répertoire / Directory / Directorio / 包装清单

## English

Disclaimer .....	02
Statement .....	02
Packing List .....	03
Installation steps .....	04
Use of heightening feet .....	08
Connect the cable .....	09
LaserGRBL modify Y-axis maximum travel value .....	11
LightBurn modify Y-axis maximum travel value .....	12

## Deutsch

Verzichtserklärung .....	15
Aussage .....	15
Packliste .....	16
Installationsschritte .....	17
Verwendung von Erhöhungsfüßen .....	21
Schließen Sie das Kabel an .....	22
LaserGRBL modifiziert den maximalen Verfahrensweg der Y-Achse .....	24
LightBurn ändert den maximalen Verfahrensweg der Y-Achse .....	25

## Français

Branchez le câble .....	28
Déclaration .....	28
Liste de colisage .....	29
Étapes d'installation .....	30
Utilisation de pieds rehausseurs .....	34
Branchez le câble .....	35
LaserGRBL modifie la valeur de déplacement maximale de l'axe Y .....	37
LightBurn modifie la valeur de déplacement maximale de l'axe Y .....	38

## Italia

Disconoscimento .....	41
Affermazione .....	41
Bolla di accompagnamento .....	42
Fasi di installazione .....	43
Utilizzo di piedini di rialzo .....	47
Collegare il cavo .....	48
LaserGRBL modifica il valore massimo della corsa dell'asse Y .....	50
LightBurn modifica il valore massimo della corsa dell'asse Y .....	51

## Español

Renuncia .....	54
Declaración .....	54
Lista de empaque .....	55
Pasos de instalación .....	56
Uso de pies de elevación .....	60
Conecte el cable .....	61
LaserGRBL modifica el valor máximo de recorrido del eje Y .....	63
LightBurn modifica el valor máximo de recorrido del eje Y .....	64

## 中文

免责声明 .....	67
注意事项 .....	67
产品清单 .....	68
机器安装步骤 .....	69
增高脚的使用 .....	73
接线 .....	74
LaserGRBL修改Y轴行程参数 .....	76
LightBurn修改Y轴行程步骤 .....	77

## Disclaimer

This product is not a toy and is not suitable for people under 15 years of age.

This product is a conveyor , visit <http://www.atomstack.com/> for complete "user manual" and the latest instructions and warnings. AtomStack reserves the right to update this Disclaimer and Safe Operation Guidelines.

Please be sure to read this document carefully before using the product to understand your legal rights, responsibilities and safety instructions; Otherwise, it may bring property loss, safety accident and hidden danger of personal safety. Once you use this product, you shall be deemed to have understood and accepted all terms and contents of this document. User undertakes to be responsible for his or her actions and all consequences arising therefrom. User agrees to use the Product only for legitimate purposes and agrees to all terms and contents of this document and any relevant policies or guidelines that AtomStack may establish. You understand and agree that AtomStack may not be able to provide you with the cause of the damage or accident and provide you with AtomStack's after-sale service unless you provide the original engraving or cutting files, engraving software configuration parameters used, operating system information, video of the engraving or cutting process, and operational steps prior to the occurrence of a problem or failure.

AtomStack is not liable for any and all losses arising from the user's failure to use the product in accordance with this manual.

AtomStack has the ultimate right to interpret the document, subject to legal compliance. AtomStack reserves the right to update, modify, or terminate the Terms without prior notice.

## Statement

The engraving function requires LightBurn to control, please download the official version of the LightBurn software. LightBurn is third-party software, so the ATOMSTACK service is not responsible for any loss caused by the operation of LightBurn, ATOMSTACK's firmware has been tested in detail by ATOMSTACK, and incompatibility with software or hardware may still occur. If an error occurs due to incompatibility, you can contact our customer service department for technical support.support@atomstack.com

# Packing List

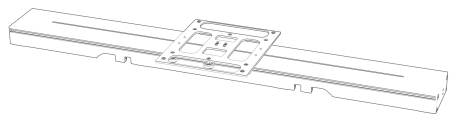

Bottom Component



Threaded heightening legs 1

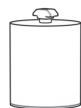

Threaded heightening legs 2

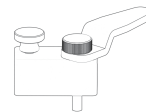

Fixing component 4pcs



Brush



M4\*6 (32pcs)

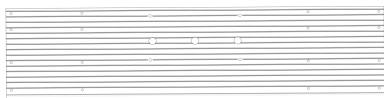

Left Side panel



Knurled Head Screw 4pcs



Heightened foot support base (long)



M5\*6 (8pcs)



Right Side panels



user manual



Heightened foot support base (short)

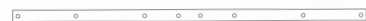

Reinforcing plate 4pcs



H2.5, H3 hexagonal wrench



Reverse sequence motor cable



Conveyor motor connection cable



Fixing piece (long) 2PCS

## Installation steps

### step : 1

Align the left side panel and the right side panel

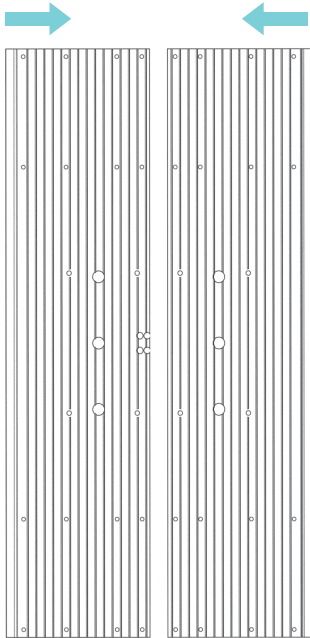

### step : 2

Lock the Reinforcing plates underneath the panels one by one with 32pcs M4\*6 screws .

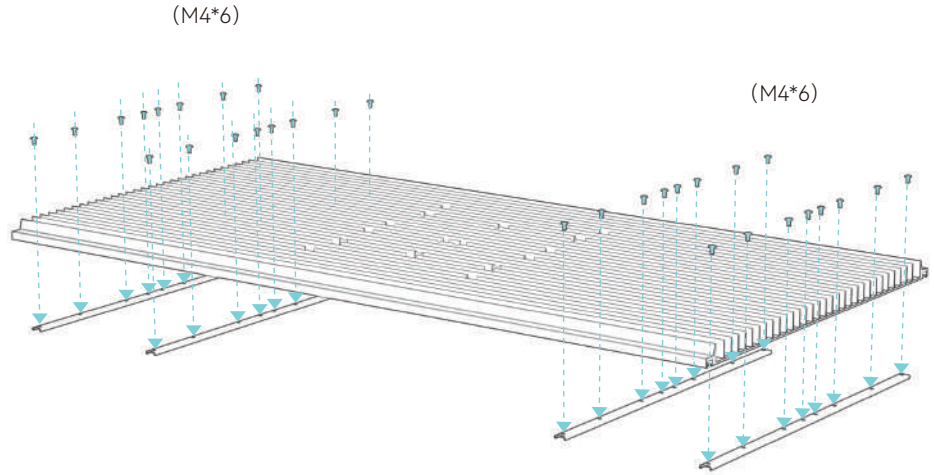

### step : 3

Install the assembled panel to bottom component with 8pcs M5\*10 screws

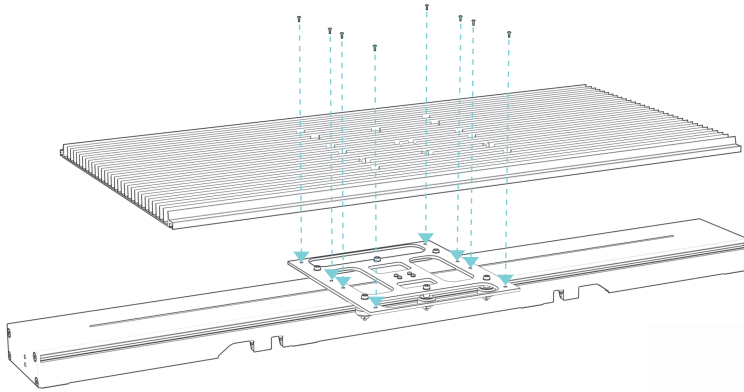

### step : 4

#### Fixing component instruction

1) Install 4 fixing components from the edge of the panel in the direction as shown

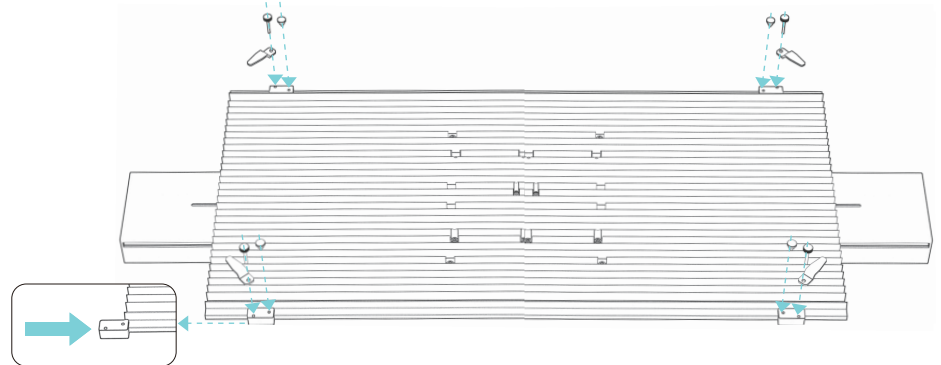



2) Use the fixing components directly when engraving 340-370mm wide objects

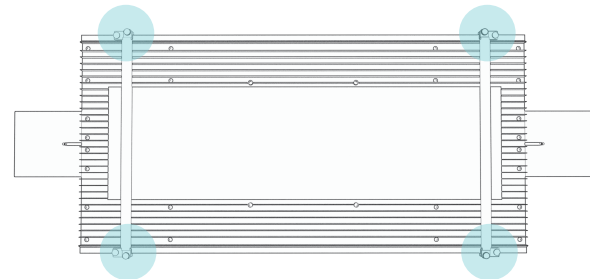
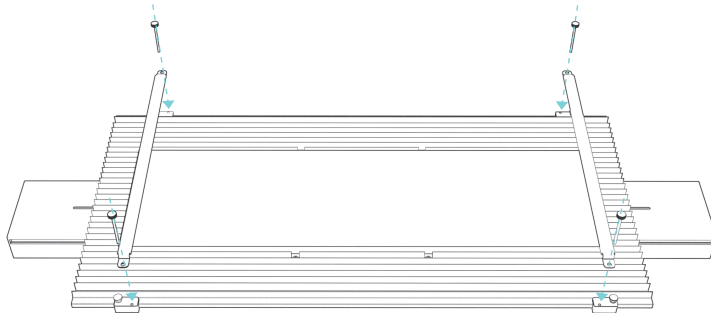

## step : 5

Align the conveyor downwards with the holes and press directly into the foot holder.

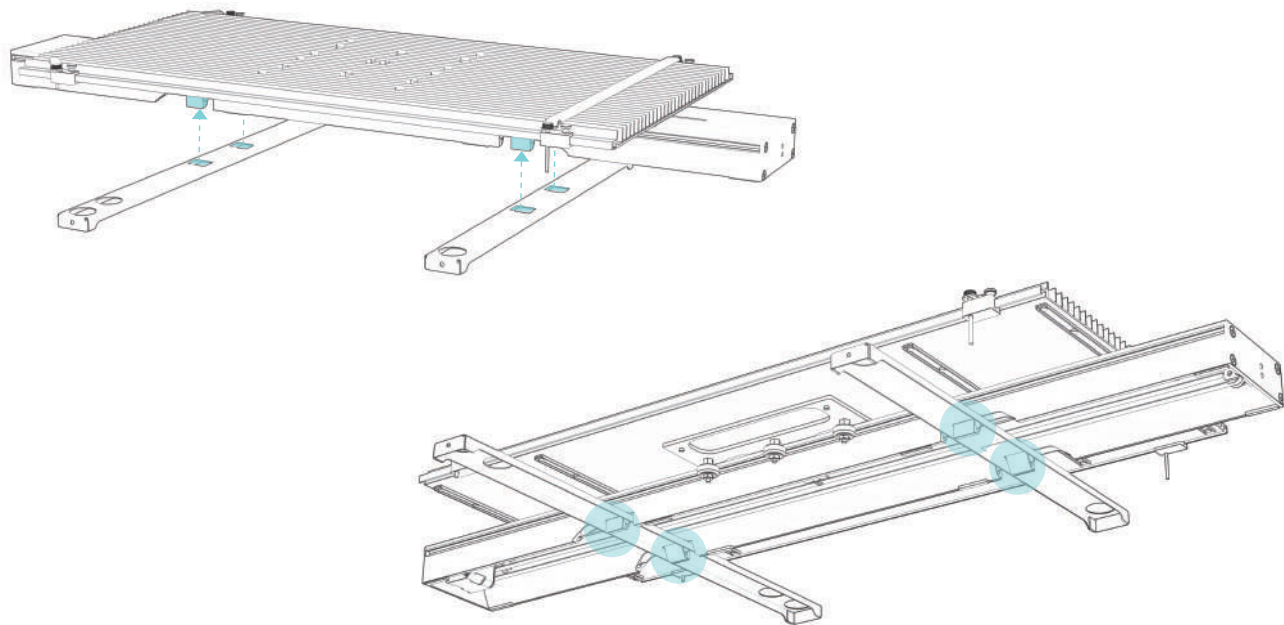



## Risers instruction

### Method 1:

If the engraver has reserved screw holes, please install the 4 risers as shown in photos, And used with the foot fixation bracket.

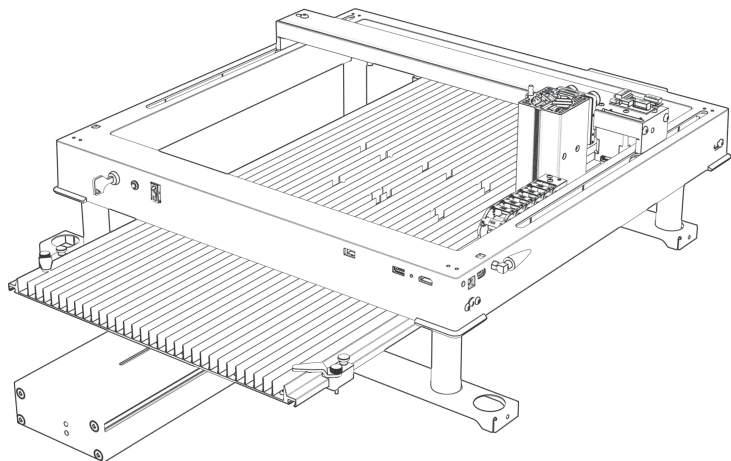

### Method 2:

If the engraver feet are pieces like below, please install as shown in photo And used with the foot fixation bracket.

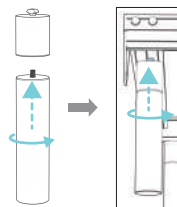

Follow the steps to install the heightening feet

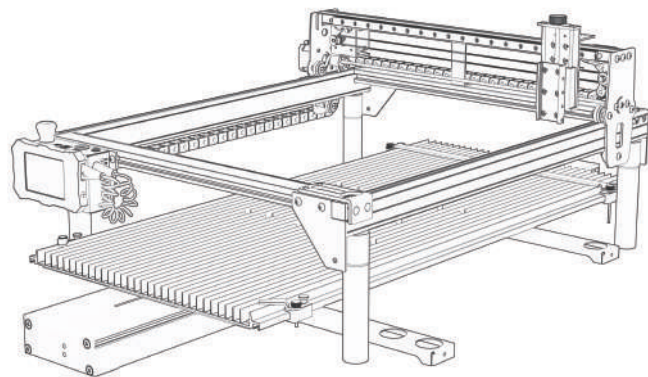

## Connect the cable

### Wiring method 1: (When your engraving machine has a Y-axis switching port)

1. Locate the switch on lower right corner of engraver, unplug the connector.
2. Pull out the conveyor harness. Position switch and Y-axis switching port connecting the conveyor and engraving machine.
3. After plugging in the cable, flip the Y-axis switch downward.

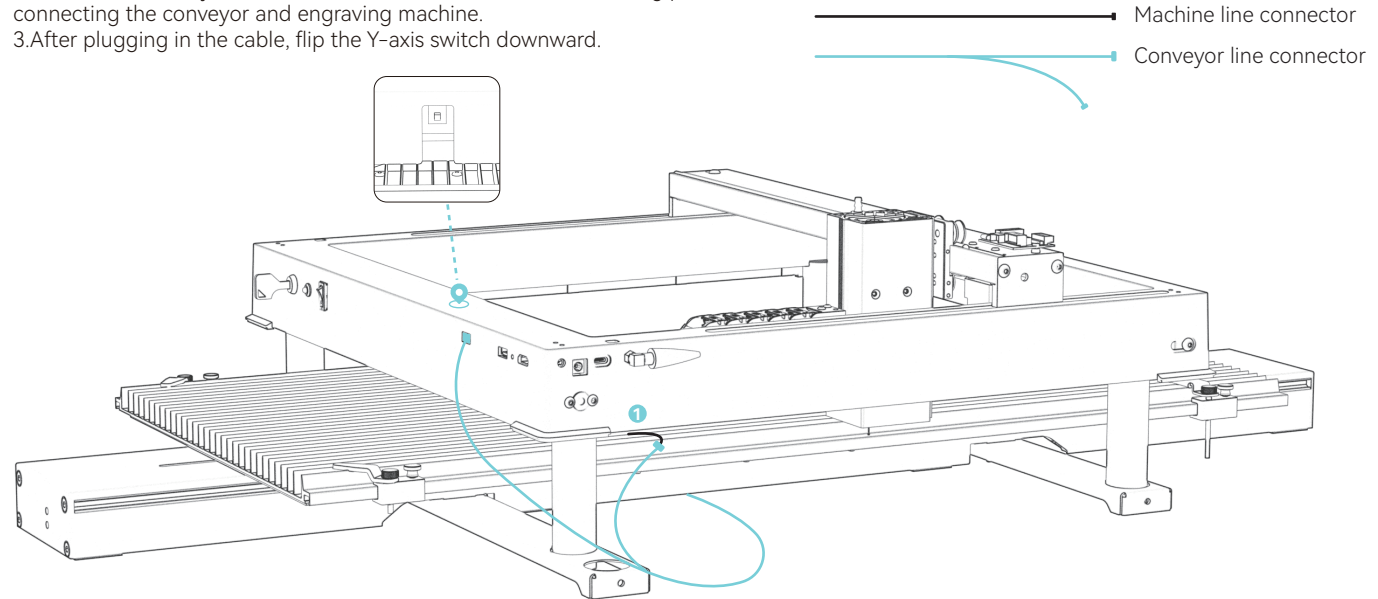

## Wiring method two : (When your engraving machine does not have a Y-axis switching port)

- 1.Pull out the conveyor harness.
- 2.Unplug the wiring at location ①,Use an adapter cable to connect certain models (the engraving machine will cause the conveyor to reverse.It is necessary to connect another sequence conversion line to the motor line).
- 3.Pull out the wire at the limit switch and connect it ②

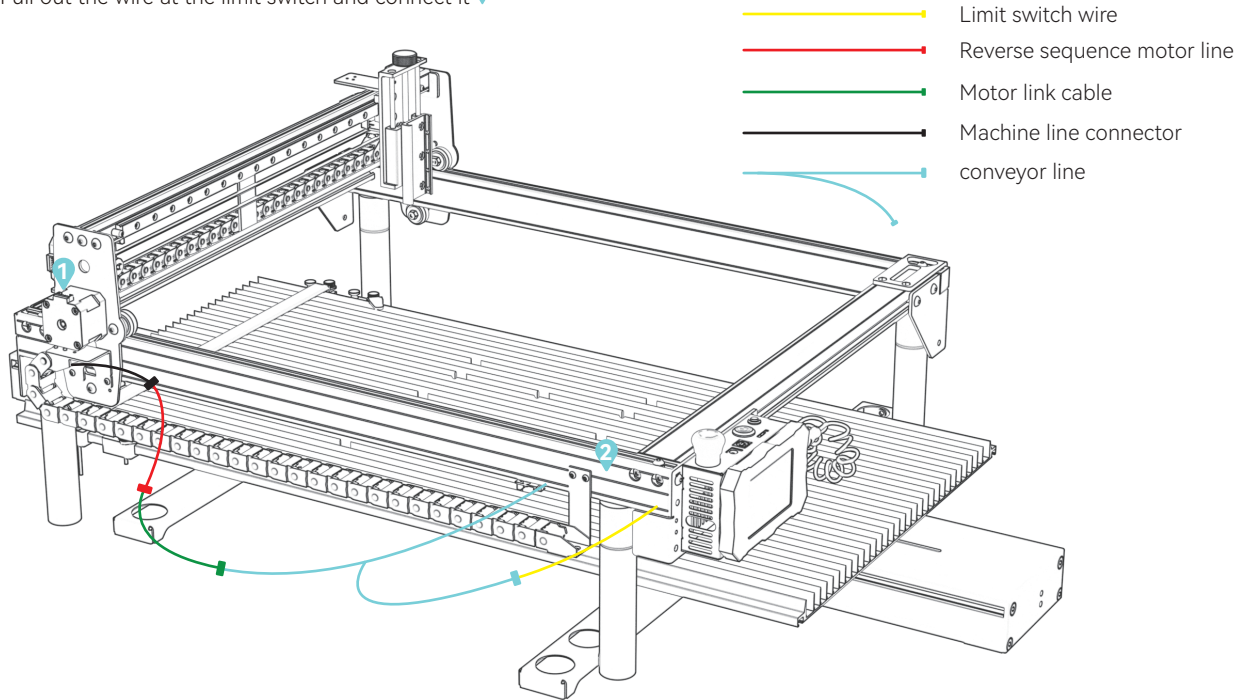

# LaserGRBL modify Y-axis maximum travel value

(1) Run LaserGRBL software, connect to engraver

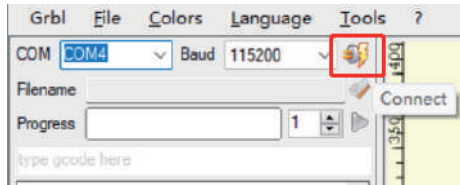

(2) Go to Grbl Configuration under Grbl menu

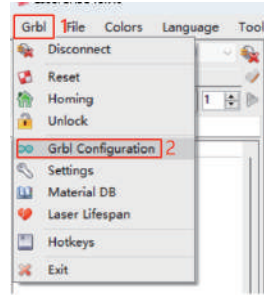

(3) Locate \$131, modify the Y-axis maximum travel value to 800

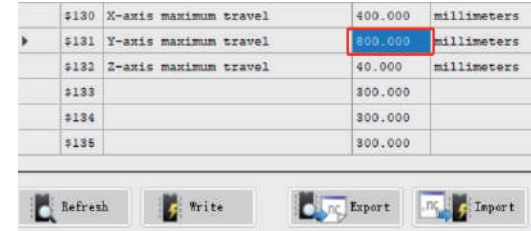

(4) Click Write

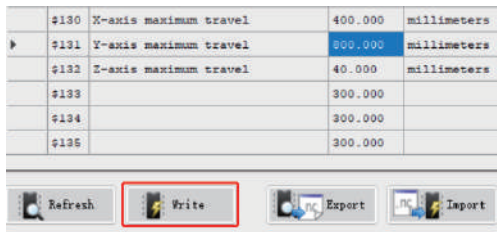

(5) Close the window after modification is completed

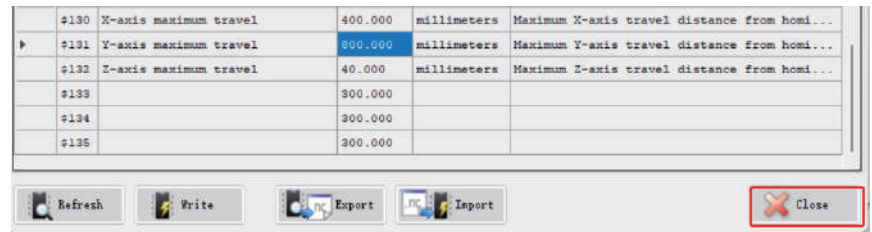

(6) Notes: When the conveyor is not in use, \$131 value needs to be modified back to default value

# LightBurn modify Y-axis maximum travel value

1.Run LightBurn, connect to engraver, "Ready" displayed at 2 indicates connection succeed

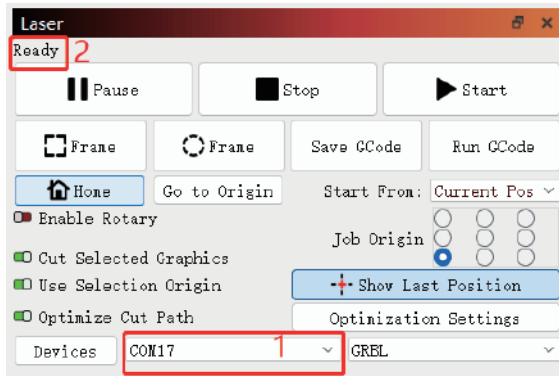

2.Go to Machine Settings under Edit menu

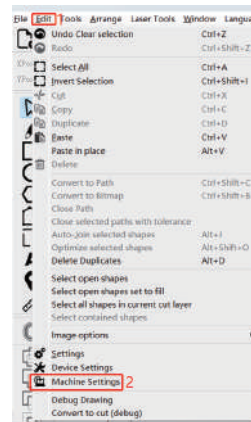

3.Expand output, locate Y max travel(m-m)(\$131), modify the value to 800, click Write then OK to finish

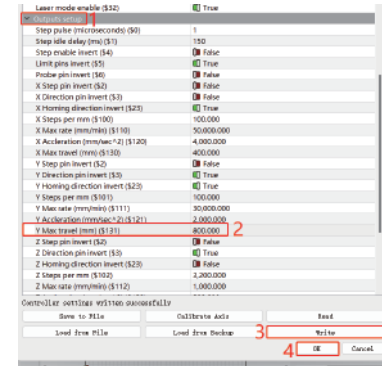

(4)Notes: When the conveyor is not in use, \$131 value needs to be modified back to default value



**Customer service :**

For detailed warranty policy, please visit our official website: [www.atomstack.com](http://www.atomstack.com)

For technical support and service, please email : [support@atomstack.com](mailto:support@atomstack.com)

**Manufacturer :**

Shenzhen atomstack Technologies Co., Ltd.

**Address :**

17th Floor, Building 3A, Phase II, Intelligent Park, No. 76, Baohe Avenue,  
Baolong Street, Longgang District, Shenzhen, Guangdong, China

**Zip code:** 518172

**Scan QR code :**

Scan with QR code reader/barcode scanner or any app with scanner



**ATOMSTACK**

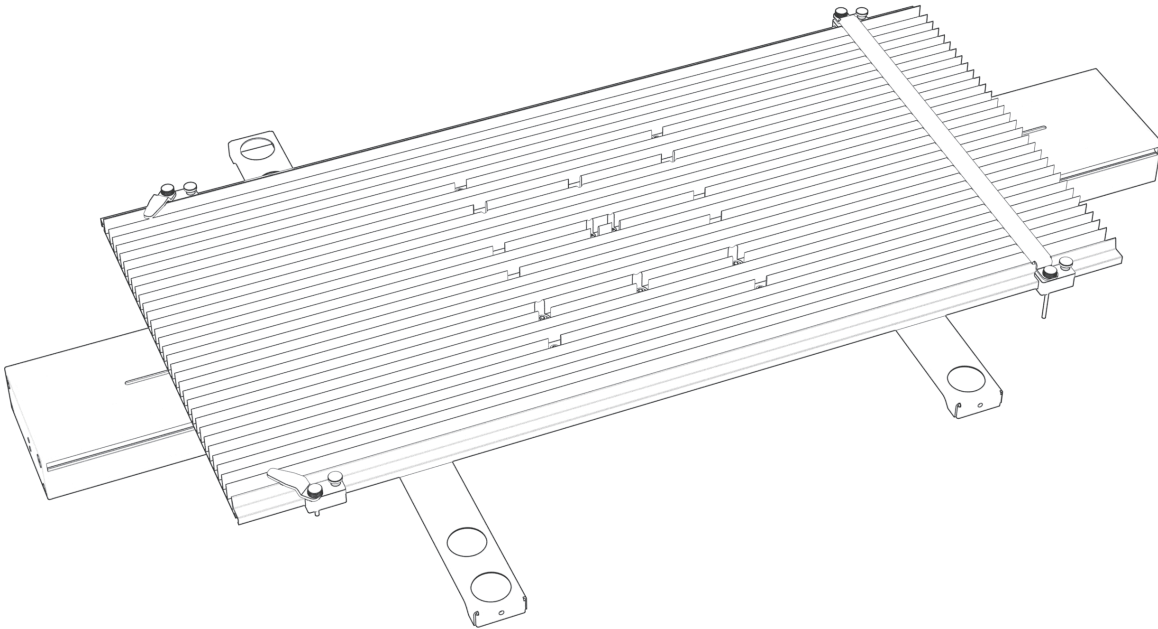

## **R5 Conveyor Benutzerhandbuch**

# Verzichtserklärung

Dieses Produkt ist kein Spielzeug und nicht für Personen unter 15 Jahren geeignet.

Bei diesem Produkt handelt es sich um ein Förderband, besuchen Sie <http://www.atomstack.com/> für die vollständige "Bedienungsanleitung" und die neuesten Anweisungen und Warnungen. AtomStack behält sich das Recht vor, diesen Haftungsausschluss und die Richtlinien für den sicheren Betrieb zu aktualisieren.

Bitte lesen Sie dieses Dokument sorgfältig durch, bevor Sie das Produkt verwenden, um Ihre gesetzlichen Rechte, Pflichten und Sicherheitsanweisungen zu verstehen. Andernfalls kann es zu Sachschäden, Sicherheitsunfällen und versteckten Gefahren für die persönliche Sicherheit kommen. Sobald Sie dieses Produkt verwenden, wird davon ausgegangen, dass Sie alle Bedingungen und Inhalte dieses Dokuments verstanden und akzeptiert haben. Der Nutzer verpflichtet sich, für seine Handlungen und alle sich daraus ergebenden Folgen verantwortlich zu sein. Der Benutzer erklärt sich damit einverstanden, das Produkt nur für legitime Zwecke zu verwenden, und stimmt allen Bedingungen und Inhalten dieses Dokuments sowie allen relevanten Richtlinien oder Richtlinien zu, die AtomStack festlegen kann. Sie verstehen und erklären sich damit einverstanden, dass AtomStack möglicherweise nicht in der Lage ist, Ihnen die Ursache des Schadens oder Unfalls mitzuteilen und Ihnen den Kundendienst von AtomStack zur Verfügung zu stellen, es sei denn, Sie stellen die Original-Gravur- oder Schneidedateien, die verwendeten Konfigurationsparameter der Gravursoftware, Betriebssysteminformationen, ein Video des Gravur- oder Schneidevorgangs und die Betriebsschritte vor dem Auftreten eines Problems oder Fehlers zur Verfügung.

AtomStack haftet nicht für alle Verluste, die sich daraus ergeben, dass der Benutzer das Produkt nicht in Übereinstimmung mit diesem Handbuch verwendet.

AtomStack hat das letztendliche Recht, das Dokument zu interpretieren, vorbehaltlich der Einhaltung der gesetzlichen Bestimmungen. AtomStack behält sich das Recht vor, die Bedingungen ohne vorherige Ankündigung zu aktualisieren, zu ändern oder zu beenden.

# Aussage

Für die Steuerung der Gravurfunktion ist LightBurn erforderlich, bitte laden Sie die offizielle Version der LightBurn-Software herunter. LightBurn ist Software von Drittanbietern, daher ist der ATOMSTACK-Dienst nicht verantwortlich für Verluste, die durch den Betrieb von LightBurn verursacht werden, die Firmware von ATOMSTACK wurde von ATOMSTACK im Detail getestet und es kann immer noch zu Inkompatibilitäten mit Software oder Hardware kommen. Sollte aufgrund einer Inkompatibilität ein Fehler auftreten, können Sie sich für technische [support@atomstack.com](mailto:support@atomstack.com) an unseren Kundendienst wenden



# Packliste

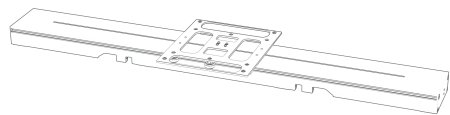

Untere Komponente



Gewinde-Erhöhungsbeine 1



Gewinde-Erhöhungsbeine 2

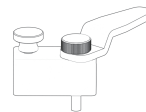

Befestigungskomponente 4 Stück



Bürsten



M4\*6 (32pcs)

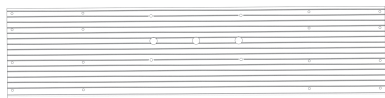

Linkes Seitenteil



Knurled Head Screw 4pcs



Erhöhte Fußstützbasis (lang)



M5\*6 (8pcs)



Rechte Seitenwände



Benutzerhandbuch



Erhöhte Fußstützbasis (kurz)



Verstärkungsplatte 4 Stück



H2.5, H3 Sechskantschlüssel



Motorkabel in umgekehrter Reihenfolge



Anschlusskabel Fördermotor



Befestigungsstück (lang) 2 Stück

# Installationsschritte

## Schritt : 1

Richten Sie die linke und die rechte Seitenwand aus

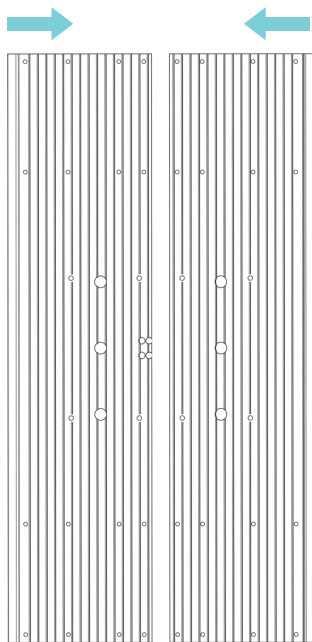

## Schritt : 2

Befestigen Sie die Verstärkungsplatten unter den Paneelen nacheinander mit 32 Stück M4 \* 6 Schrauben .

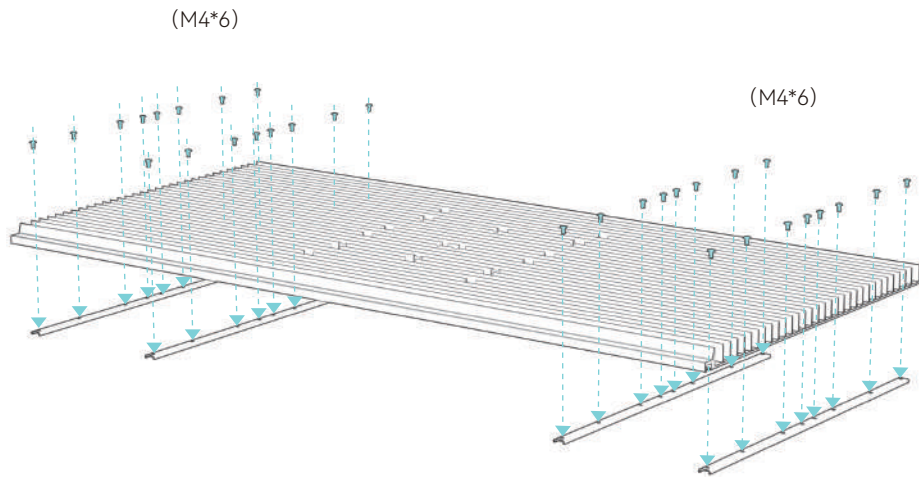

## Schritt : 3

Montieren Sie die montierte Platte mit 8 Stück M5\*10-Schrauben an der unteren Komponente.

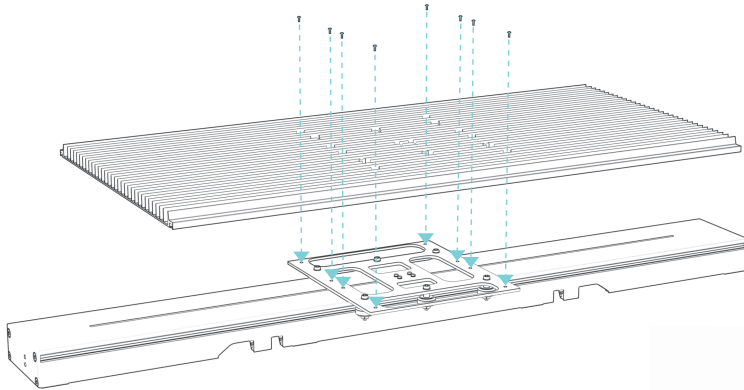

## Schritt : 4

### Anleitung zum Fixieren von Bauteilen

1) Montieren Sie 4 Befestigungselemente von der Kante der Platte in Richtung wie gezeigt

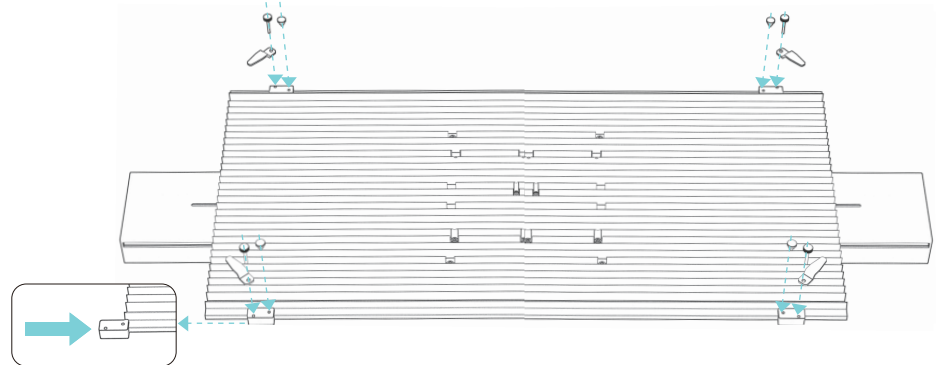



2) Verwenden Sie die Befestigungskomponenten direkt beim Gravieren von 340-370 mm breiten Objekten

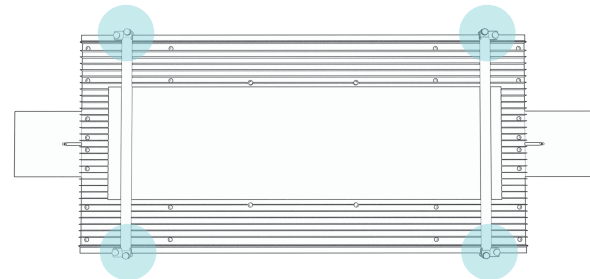
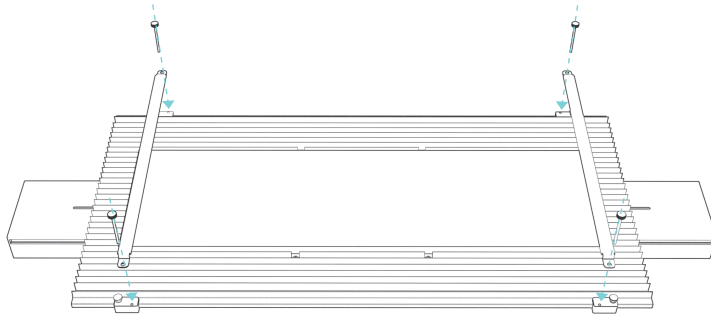

## Schritt : 5

Richten Sie das Förderband mit den Löchern nach unten aus und drücken Sie es direkt in den Fußhalter.

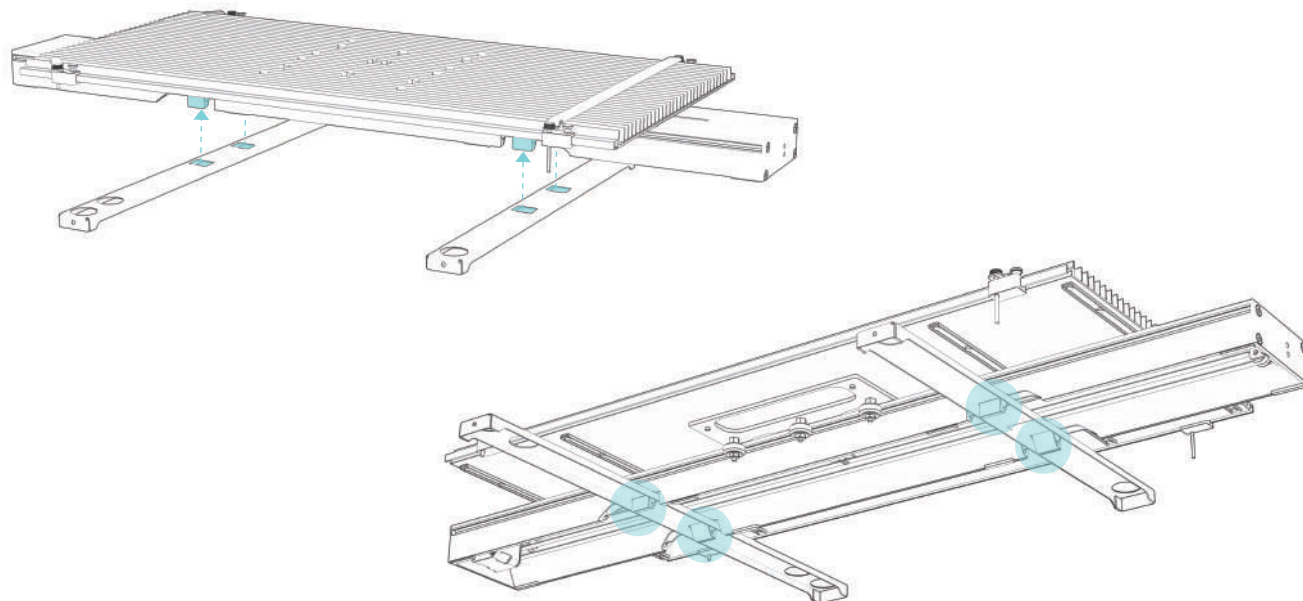

# Verwendung von Erhöhungsfüßen

## Method 1:

Wenn der Gravierer reservierte Schraubenlöcher hat, installieren Sie bitte die 4 Riser wie auf den Fotos gezeigt und verwenden Sie sie mit der Fußbefestigungshalterung.

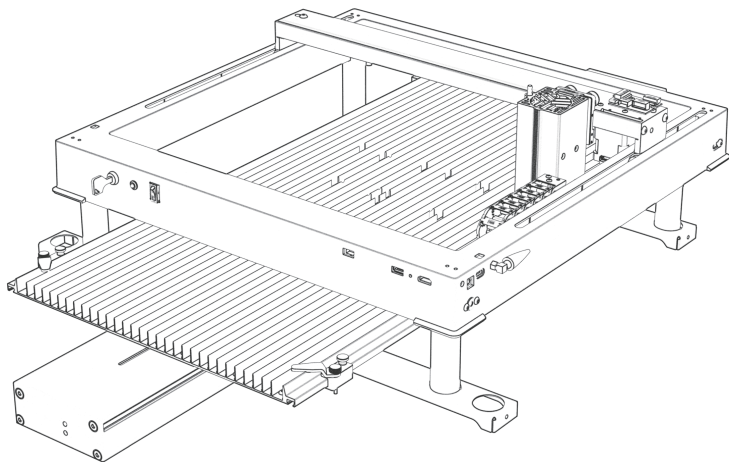

## Method 2:

Wenn es sich bei den Gravierfüßen um Stücke wie unten handelt, installieren Sie sie bitte wie auf dem Foto gezeigt und verwenden Sie sie mit der Fußbefestigungshalterung.

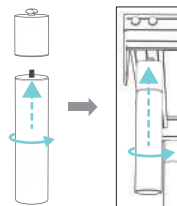

Befolgen Sie die Schritte, um die Erhöhungsfüße zu installieren

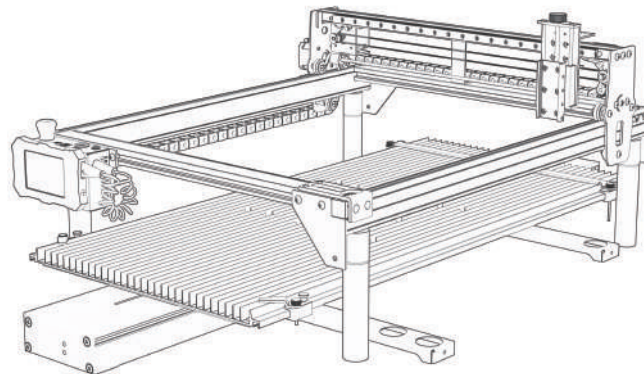



# Schließen Sie das Kabel an

## Verdrahtungsmethode 1: (Wenn Ihre Graviermaschine über einen Y-Achsen-Schaltanschluss verfügt)

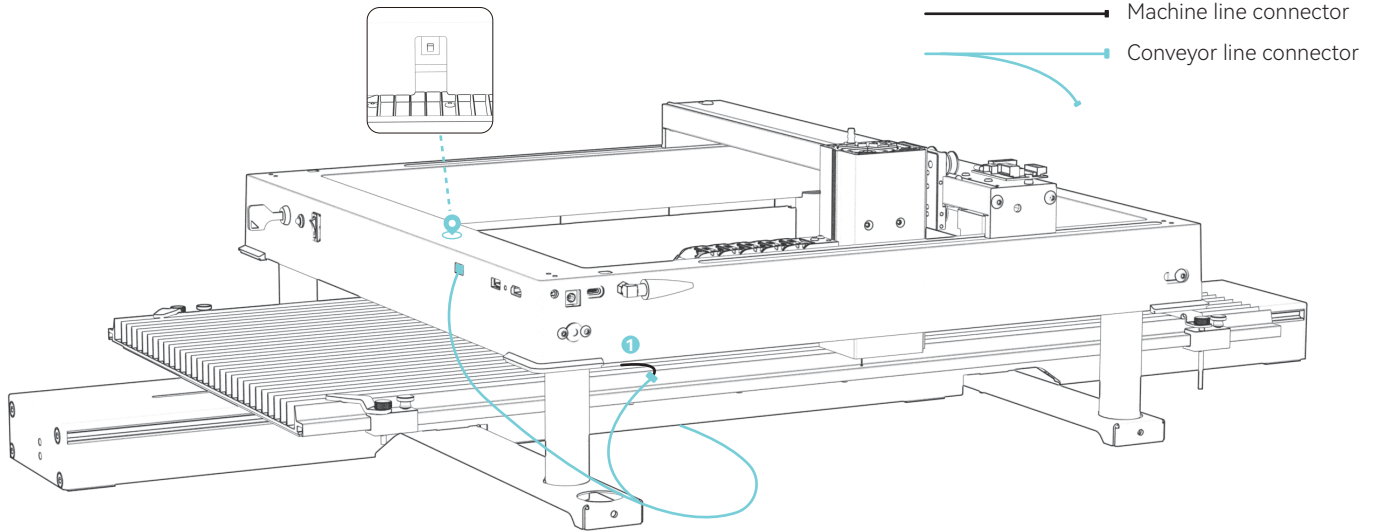



1. Suchen Sie den Schalter in der unteren rechten Ecke des Gravierers und ziehen Sie den Stecker ab.
2. Ziehen Sie den Förderkabelbaum heraus. Positionsschalter und Y-Achsen-Schaltanschluss zur Verbindung von Förderband und Graviermaschine.
3. Drehen Sie nach dem Einstecken des Kabels den Y-Achsen-Schalter nach unten.

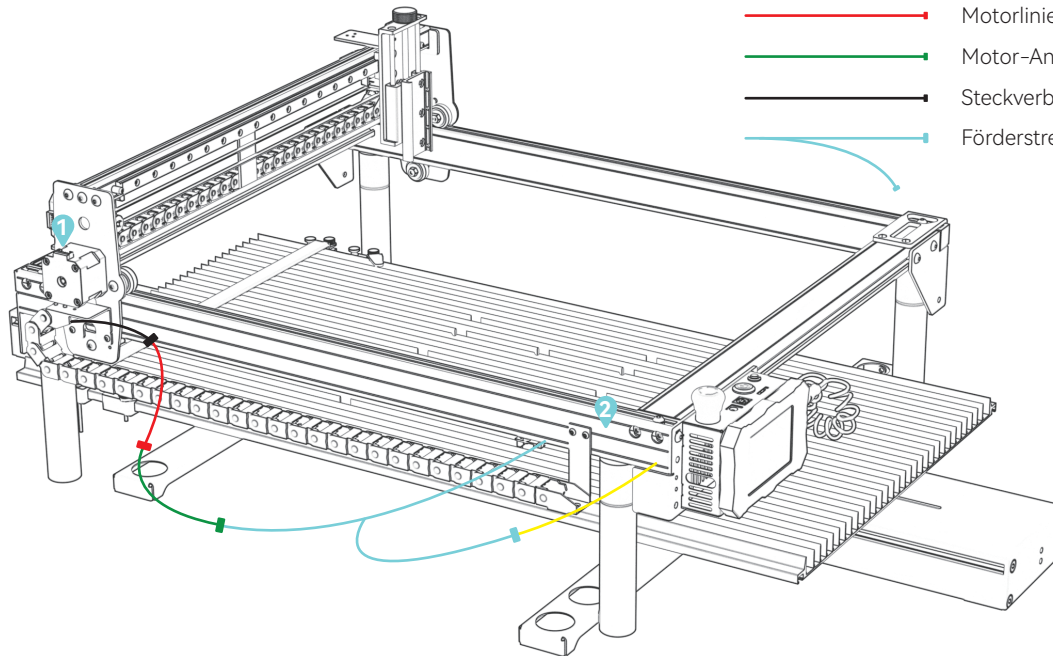

## Verdrahtungsmethode 2 : (Wenn Ihre Graviermaschine nicht über einen Y-Achsen-Schaltanschluss verfügt)

1. Ziehen Sie den Förderkabelbaum heraus.
2. Ziehen Sie den Stecker der Verkabelung vor Ort , verwenden Sie ein Adapterkabel, um bestimmte Modelle anzuschließen (Die Graviermaschine bewirkt, dass das Förderband rückwärts fährt. Es ist notwendig, eine weitere Sequenzumwandlungsleitung an die Motorleitung anzuschließen).
3. Ziehen Sie das Kabel am Endschalter heraus und schließen Sie es an .



-  Endschalter-Draht
-  Motorlinie mit umgekehrter Sequenz
-  Motor-Anschlusskabel
-  Steckverbinder für Maschinenleitungen
-  Förderstrecke



# LaserGRBL modifiziert den maximalen Verfahrensweg der Y-Achse

(1) Führen Sie die LaserGRBL-Software aus, stellen Sie eine Verbindung zum Gravierer her

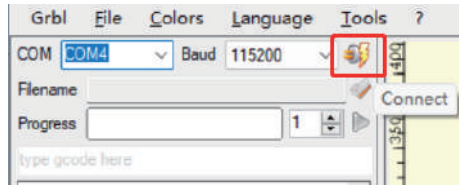

(2) Gehen Sie zur Grbl-Konfiguration im Grbl-Menü

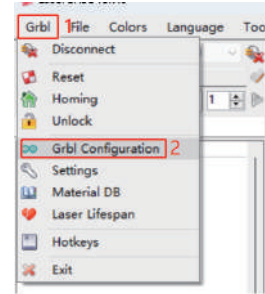

(3) Suchen Sie \$131, und ändern Sie den maximalen Verfahrensweg der Y-Achse auf 800

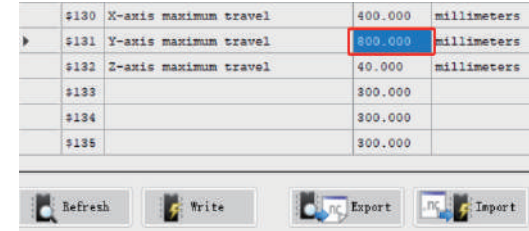

(4) Klicken Sie auf Schreiben

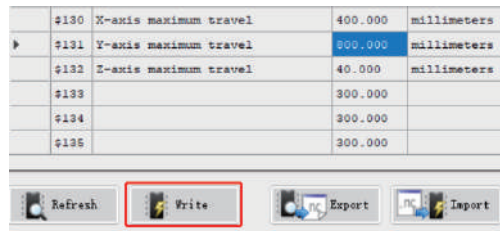

(5) Schließen Sie das Fenster, nachdem die Änderung abgeschlossen ist

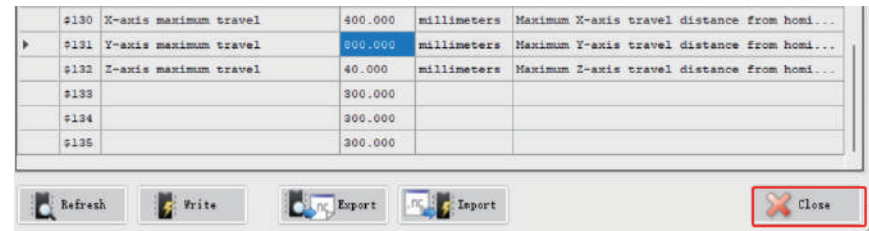

(6) Hinweise: Wenn das Förderband nicht verwendet wird, muss der Wert von 131 \$ wieder auf den Standardwert zurückgesetzt werden

# LightBurn ändert den maximalen Verfahrensweg der Y-Achse

1. Führen Sie LightBurn aus, stellen Sie eine Verbindung zum Gravierer her, "Bereit" wird bei 2 angezeigt und zeigt an, dass die Verbindung erfolgreich war

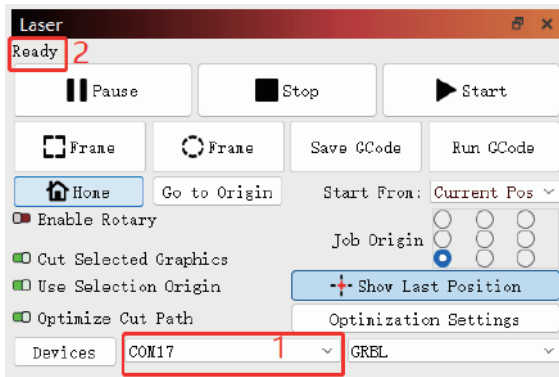

2. Gehen Sie zu den Maschineneinstellungen unter Edit nenu

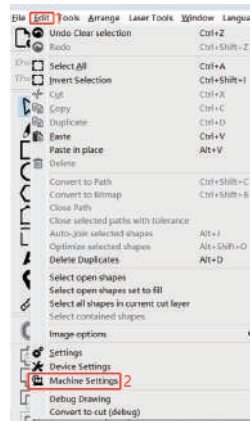

3. Erweitern Sie die Ausgabe, suchen Sie den maximalen Verfahrensweg von Y (mm) (\$131), ändern Sie den Wert in 800, klicken Sie auf Schreiben und dann auf OK, um den Vorgang abzuschließen

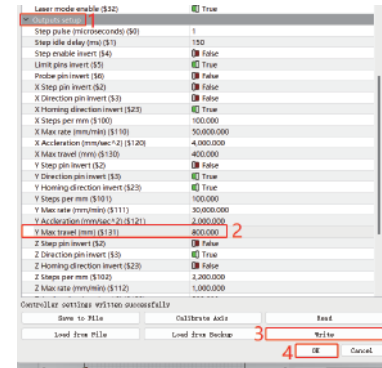

(4) Hinweise: Wenn das Förderband nicht verwendet wird, muss der Wert von 131 \$ wieder auf den Standardwert zurückgesetzt werden



### **Kundendienst:**

Detaillierte Garantiebestimmungen finden Sie auf unserer offiziellen Website: [www.atomstack.com](http://www.atomstack.com)

Für technischen Support und Service senden Sie bitte eine E-Mail an : [support@atomstack.com](mailto:support@atomstack.com)

### **Hersteller:**

Lieferant:Shenzhen atomstack Technologies Co., Ltd.

### **Adresse:**

17. Etage, Gebäude 3A, Phase II, Intelligent Park, Nr. 76, Baohe Avenue, Baolong Street, Longgang District, Shenzhen, Guangdong, China

**PLZ:** 518172

### **QR-Code scannen:**

Scannen mit QR-Code-Lesegerät/Barcode-Scanner oder einer beliebigen App mit Scanner



**ATOMSTACK**

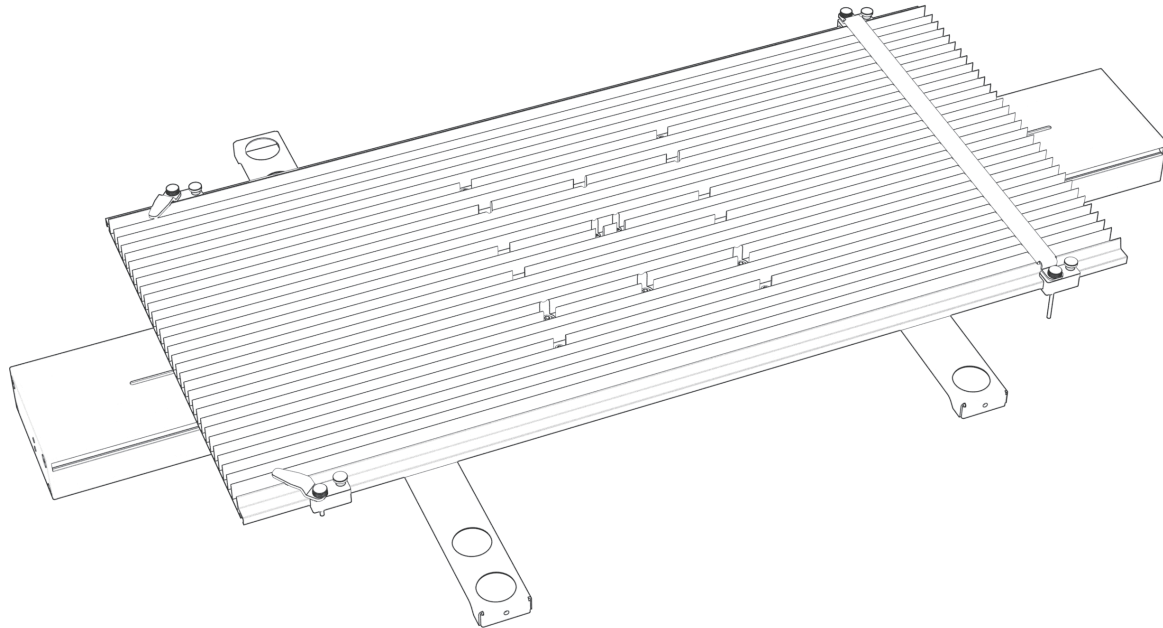

## **Convoyeur R5 Manuel d'utilisation**

# Démenti

Ce produit n'est pas un jouet et ne convient pas aux personnes de moins de 15 ans.

Ce produit est un convoyeur, visitez <http://www.atomstack.com/> pour le « manuel d'utilisation » complet et les dernières instructions et avertissements. AtomStack se réserve le droit de mettre à jour cette clause de non-responsabilité et les directives de sécurité d'utilisation.

Assurez-vous de lire attentivement ce document avant d'utiliser le produit pour comprendre vos droits légaux, vos responsabilités et vos consignes de sécurité ; Sinon, cela peut entraîner des pertes matérielles, un accident de sécurité et un danger caché pour la sécurité personnelle. Une fois que vous utilisez ce produit, vous serez réputé avoir compris et accepté tous les termes et contenus de ce document. L'utilisateur s'engage à être responsable de ses actes et de toutes les conséquences qui en découlent. L'utilisateur accepte d'utiliser le produit uniquement à des fins légitimes et accepte toutes les conditions et le contenu de ce document et toutes les politiques ou directives pertinentes qu'AtomStack peut établir. Vous comprenez et acceptez qu'AtomStack peut ne pas être en mesure de vous fournir la cause du dommage ou de l'accident et de vous fournir le service après-vente d'AtomStack à moins que vous ne fournissiez les fichiers de gravure ou de découpe originaux, les paramètres de configuration du logiciel de gravure utilisés, les informations sur le système d'exploitation, la vidéo du processus de gravure ou de découpe et les étapes opérationnelles avant l'apparition d'un problème ou d'une défaillance.

AtomStack n'est pas responsable de toutes les pertes résultant de l'incapacité de l'utilisateur à utiliser le produit conformément à ce manuel.

AtomStack a le droit ultime d'interpréter le document, sous réserve de la conformité légale. AtomStack se réserve le droit de mettre à jour, de modifier ou de résilier les Conditions sans préavis.

# Déclaration

La fonction de gravure nécessite LightBurn pour être contrôlée, veuillez télécharger la version officielle du logiciel LightBurn. LightBurn est un logiciel tiers, de sorte que le service ATOMSTACK n'est pas responsable de toute perte causée par le fonctionnement de LightBurn, le micrologiciel d'ATOMSTACK a été testé en détail par ATOMSTACK, et une incompatibilité avec le logiciel ou le matériel peut toujours se produire. Si une erreur se produit en raison d'une incompatibilité, vous pouvez contacter notre service clientèle pour support.support@atomstack.com technique

# Liste de colisage

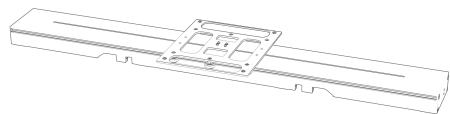

Composant inférieur



Pieds filetés rehaussants 1



Pieds filetés rehaussants 2

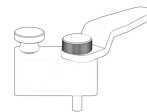

Composant de fixation 4pcs



Brosse



M4\*6 (32pcs)

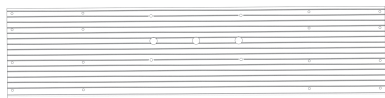

Panneau latéral gauche



Vis à tête moletée 4pcs



Base de support de pied surélevée (longue)



M5\*6 (8pcs)



Panneaux latéraux droits



Manuel



Base de soutien du pied surélevée (courte)



Plaque de renfort 4pcs



Clé hexagonale H2.5, H3



Câble moteur à séquence inverse



Câble de connexion du moteur du convoyeur



Pièce de fixation (longue) 2PCS

## Étapes d'installation

### pas : 1

Alignez le panneau latéral gauche et le panneau latéral droit

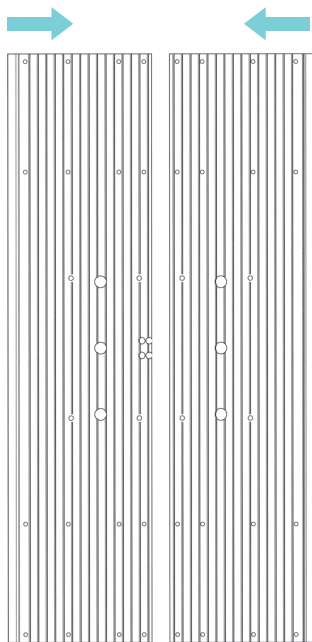

### pas : 2

Verrouillez les plaques de renfort sous les panneaux une par une avec 32 vis M4 \* 6.

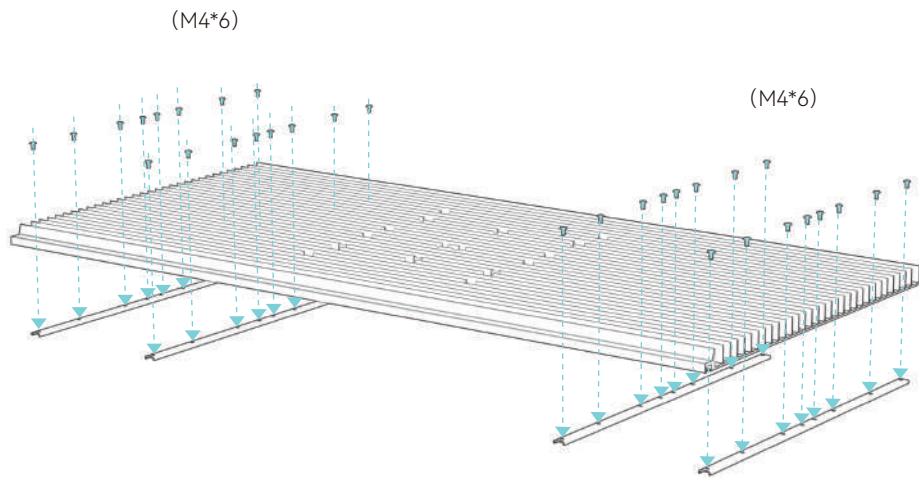

### pas : 3

Installez le panneau assemblé sur le composant inférieur avec 8 vis M5 \* 10

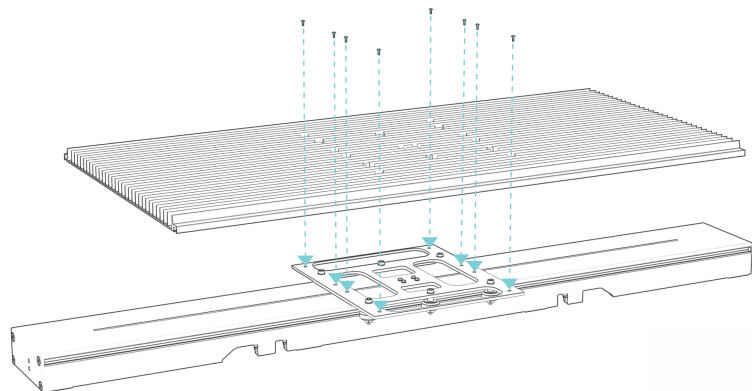

### pas : 4

#### Instructions de fixation des composants

1) Installez 4 composants de fixation à partir du bord du panneau dans le sens indiqué

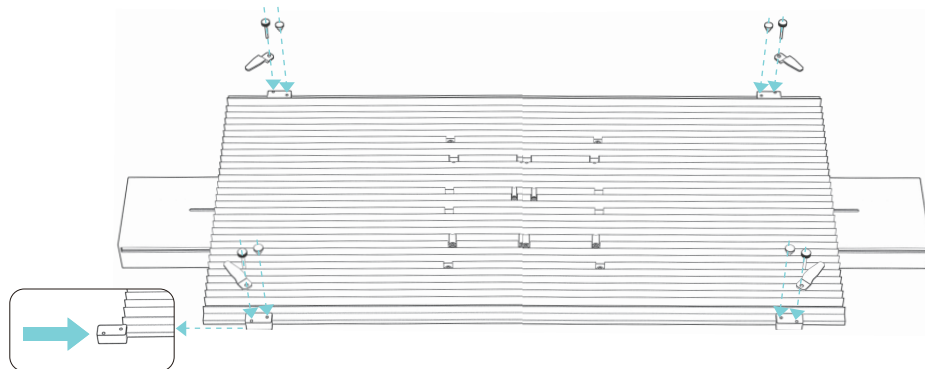





2) Utilisez directement les composants de fixation lors de la gravure d'objets de 340 à 370 mm de large

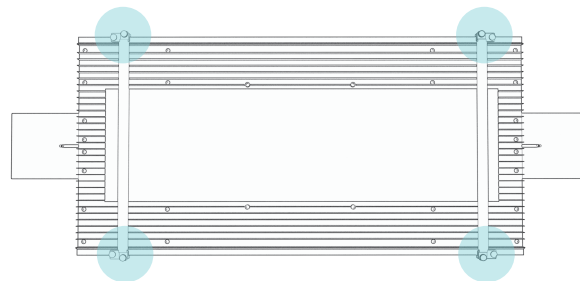
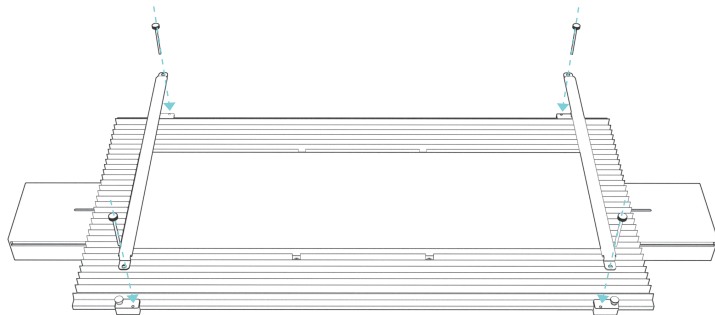

## pas : 5

Alignez le convoyeur vers le bas avec les trous et appuyez directement sur le support de pied.

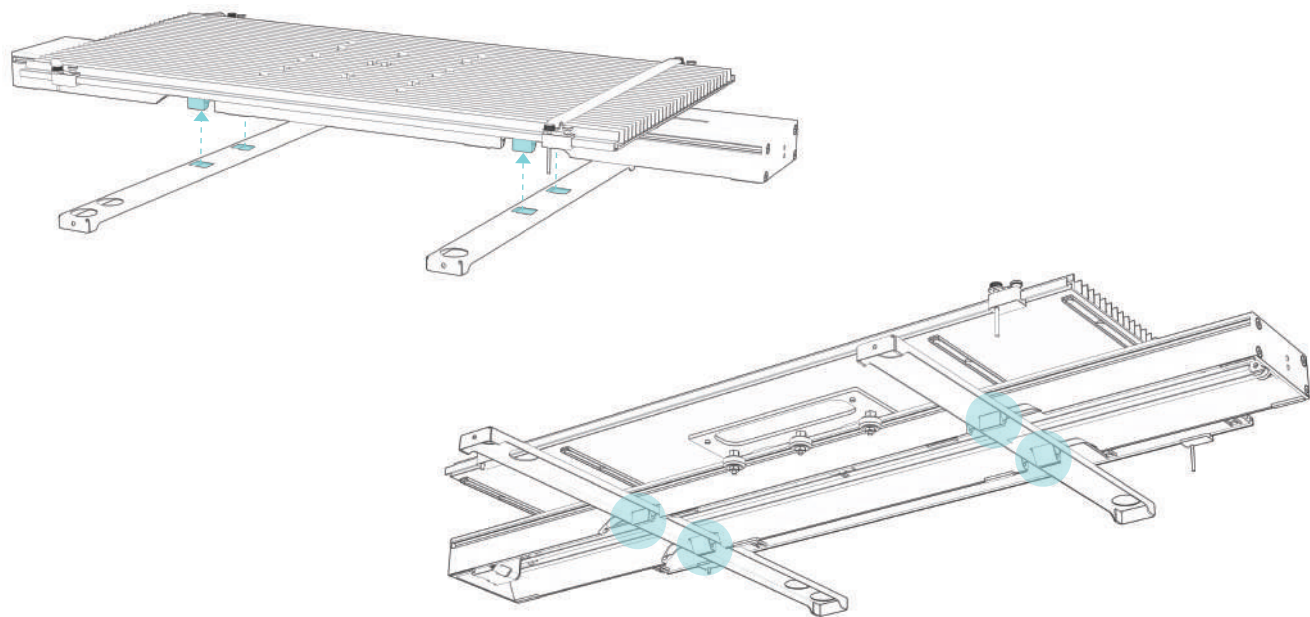

# Utilisation de pieds rehausseurs

## Méthode 1:

Si le graveur a des trous de vis réservés, veuillez installer les 4 éleveurs comme indiqué sur les photos, et utilisé avec le support de fixation du pied.

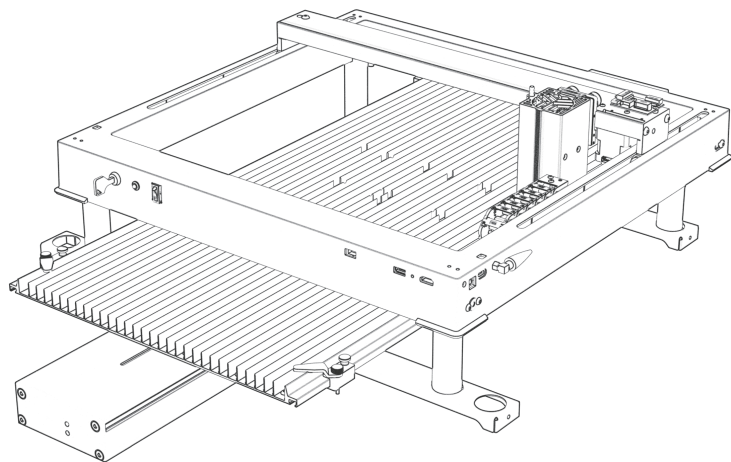

## Méthode 2:

Si les pieds du graveur sont des pièces comme ci-dessous, veuillez les installer comme indiqué sur la photo et les utiliser avec le support de fixation des pieds.

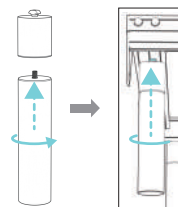

Suivez les étapes pour installer les pieds d'élevation

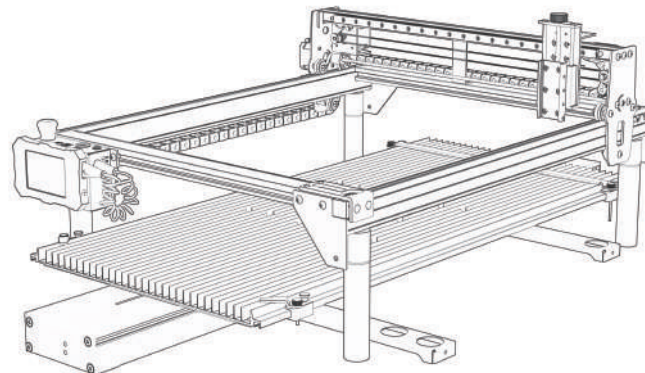



## Branchez le câble

### Méthode de câblage 1: (Lorsque votre machine de gravure dispose d'un port de commutation de l'axe Y)

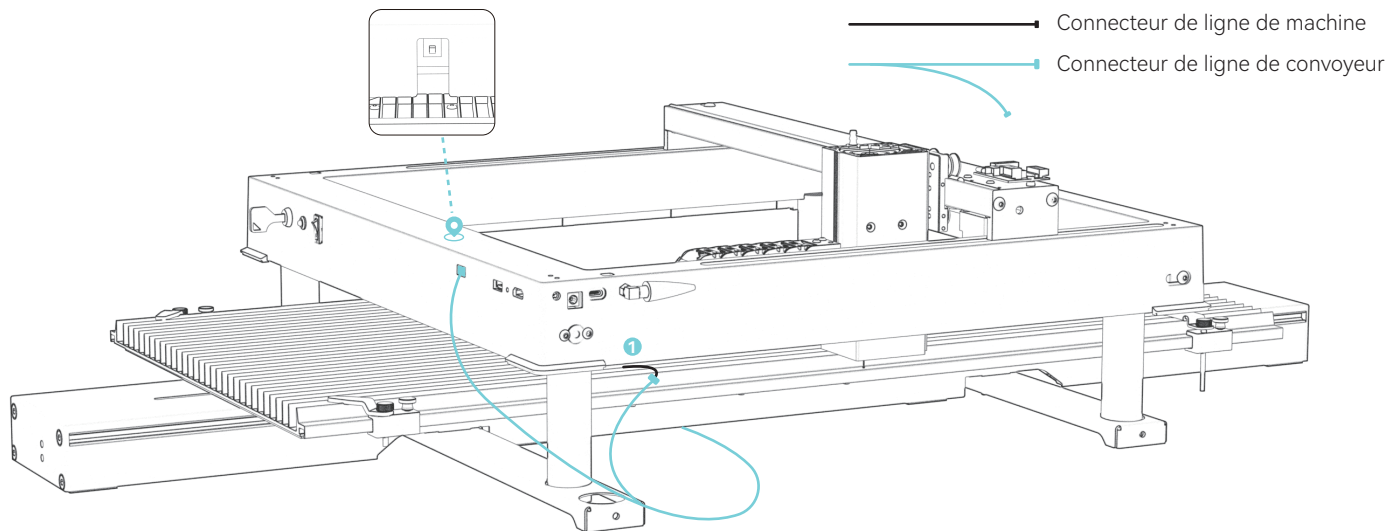
1. Localisez l'interrupteur dans le coin inférieur droit du graveur, débranchez le connecteur.
2. Retirez le faisceau du convoyeur. Commutateur de position et port de commutation de l'axe Y reliant le convoyeur et la machine de gravure.
3. Après avoir branché le câble, basculez l'interrupteur de l'axe Y vers le bas.



## Méthode de câblage 2 : (Lorsque votre machine de gravure n'a pas de port de commutation de l'axe Y)

- 1.Retirez le faisceau du convoyeur.
- 2.Débranchez le câblage à l'emplacement , Utilisez un câble adaptateur pour connecter certains modèles (La machine de gravure provoquera l'inversion du convoyeur. Il est nécessaire de connecter une autre ligne de conversion de séquence à la ligne du moteur).
- 3.Retirez le fil au niveau de l'interrupteur de fin de course et connectez-le 

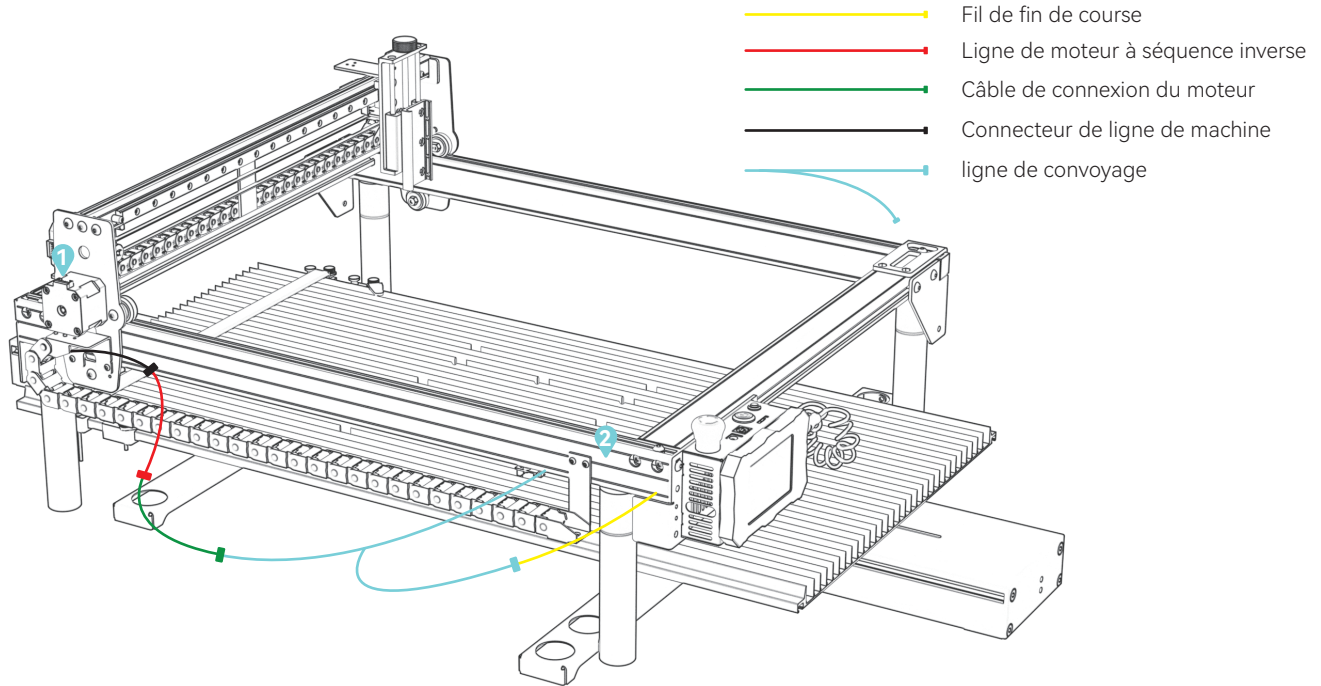

# LaserGRBL modifie la valeur de déplacement maximale de l'axe Y

(1) Exécutez le logiciel LaserGRBL, connectez-vous au graveur

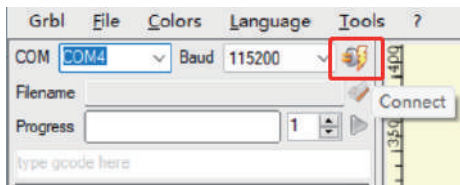

(2) Allez dans Configuration Grbl sous le menu Grbl

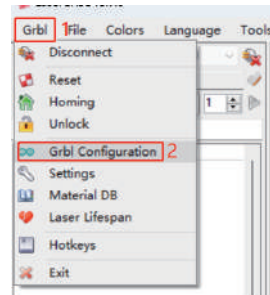

(3) Localisez \$131, modifiez la valeur de déplacement maximale de l'axe Y à 800

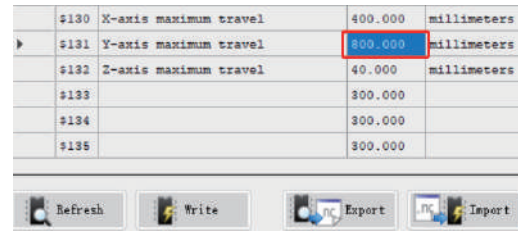

(4) Cliquez sur Écrire

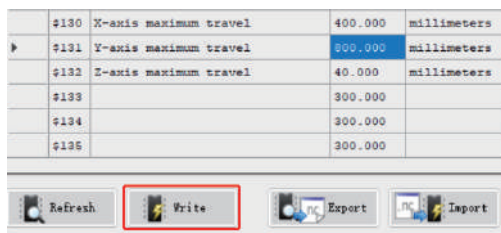

(5) Fermer la fenêtre une fois la modification terminée

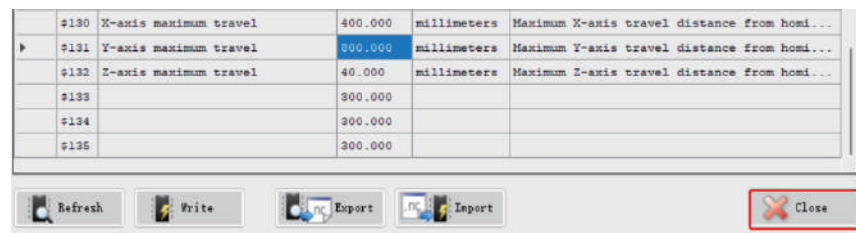

(6) Remarques : Lorsque le convoyeur n'est pas utilisé, la valeur de 131 \$ doit être modifiée pour revenir à la valeur par défaut

# LightBurn modifie la valeur de déplacement maximale de l'axe Y

1. Lancez LightBurn, connectez-vous au graveur, « Ready » s'affiche à 2 indique que la connexion a réussi

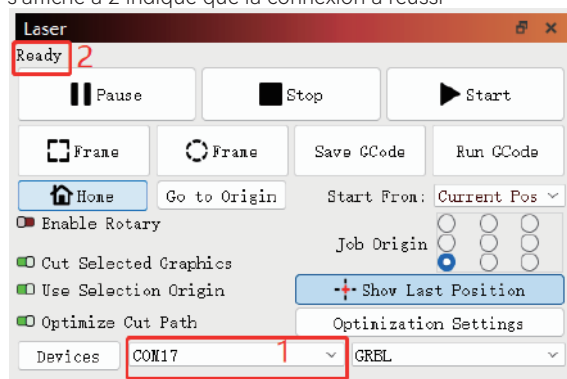

2. Allez dans Paramètres de la machine sous Modifier menu

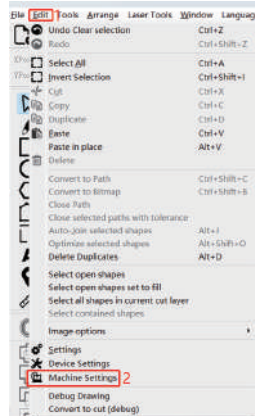

3. Développez la sortie, localisez Y course maximale (mm) (131 \$), modifiez la valeur à 800, cliquez sur Écrire puis sur OK pour terminer

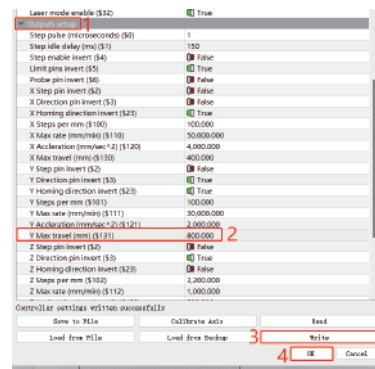

(4) Remarques : Lorsque le convoyeur n'est pas utilisé, la valeur de 131 \$ doit être modifiée pour revenir à la valeur par défaut



**Service client:**

Pour une politique de garantie détaillée, veuillez visiter notre site officiel : [www.atomstack.com](http://www.atomstack.com)  
Pour l' assistance technique et le service, veuillez envoyer un e-mail à : [support@atomstack.com](mailto:support@atomstack.com)

**Fabricant:**

Shenzhen atomstack Technologies Co., Ltd.

**Adresse:**

17e étage, bâtiment 3A, phase II, parc intelligent, n° 76, avenue Baohe, rue Baolong,  
district de Longgang, Shenzhen, Guangdong, Chine

**Code postal:** 518172

**Scanner le QR code :**

Numérisez avec un lecteur de code QR/lecteur de codes-barres ou n' importe quelle application avec scanner





**ATOMSTACK**

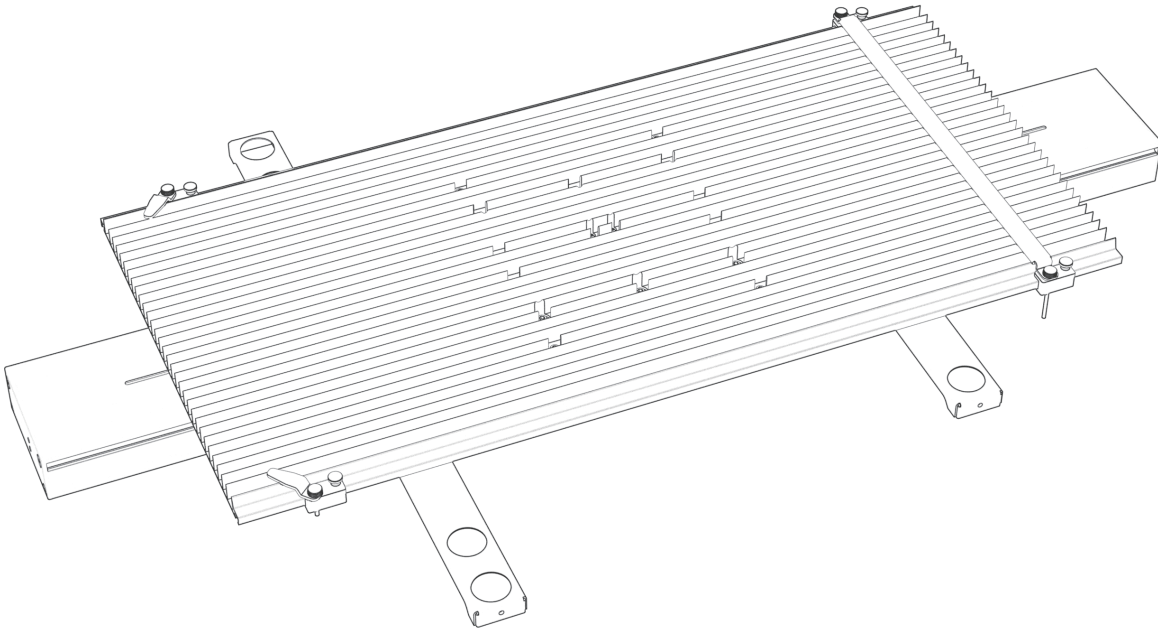

## **Manuale d'uso del trasportatore R5**

## Disconoscimento

Questo prodotto non è un giocattolo e non è adatto a persone di età inferiore ai 15 anni.

Questo prodotto è un trasportatore, visitare <http://www.atomstack.com/> per il "manuale utente" completo e le ultime istruzioni e avvertenze. AtomStack si riserva il diritto di aggiornare la presente Dichiarazione di non responsabilità e le Linee guida per il funzionamento sicuro.

Assicurati di leggere attentamente questo documento prima di utilizzare il prodotto per comprendere i tuoi diritti legali, le tue responsabilità e le istruzioni di sicurezza; In caso contrario, potrebbe causare perdita di proprietà, incidenti di sicurezza e pericolo nascosto di sicurezza personale. Una volta utilizzato questo prodotto, si riterrà che l'utente abbia compreso e accettato tutti i termini e i contenuti di questo documento. L'Utente si impegna ad essere responsabile delle proprie azioni e di tutte le conseguenze che ne derivano. L'utente accetta di utilizzare il Prodotto solo per scopi legittimi e accetta tutti i termini e i contenuti di questo documento e qualsiasi politica o linea guida pertinente che AtomStack possa stabilire. Comprendi e accetti che AtomStack potrebbe non essere in grado di fornirti la causa del danno o dell'incidente e fornirti il servizio post-vendita di AtomStack a meno che tu non fornisca i file di incisione o taglio originali, i parametri di configurazione del software di incisione utilizzati, le informazioni sul sistema operativo, il video del processo di incisione o taglio e le fasi operative prima del verificarsi di un problema o di un guasto.

AtomStack non è responsabile per tutte le perdite derivanti dal mancato utilizzo del prodotto da parte dell'utente in conformità con questo manuale.

AtomStack ha il diritto ultimo di interpretare il documento, subordinatamente alla conformità legale. AtomStack si riserva il diritto di aggiornare, modificare o risolvere i Termini senza preavviso.

## Affermazione

La funzione di incisione richiede LightBurn per essere controllata, scaricare la versione ufficiale del software LightBurn. LightBurn è un software di terze parti, quindi il servizio ATOMSTACK non è responsabile per eventuali perdite causate dal funzionamento di LightBurn, il firmware di ATOMSTACK è stato testato in dettaglio da ATOMSTACK e potrebbero ancora verificarsi incompatibilità con software o hardware. Se si verifica un errore a causa di un'incompatibilità, è possibile contattare il nostro servizio clienti per [support.support@atomstack.com](mailto:support.support@atomstack.com) tecnici

# Bolla di accompagnamento

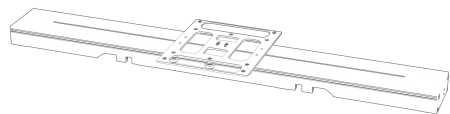

Componente inferiore



Piedini di risalita filettati 1

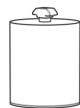

Piedini di risalita filettati 2

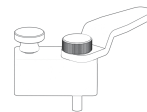

Componente di fissaggio 4pz



Spazzola



M4\*6 (32pcs)

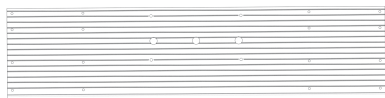

Pannello laterale sinistro



Vite a testa zigrinata 4pz



Base di appoggio per i piedi rialzata (lunga)



M5\*6 (8pcs)



Pannelli laterali destri



Manuale



Base di appoggio per i piedi rialzata (corta)



Piastra di rinforzo 4pz



Chiave esagonale H2.5, H3



Cavo motore sequenza inversa



Cavo di collegamento del motore del trasportatore



Pezzo di fissaggio (lungo) 2PCS

## Fasi di installazione

### passo : 1

Allineare il pannello laterale sinistro e il pannello laterale destro

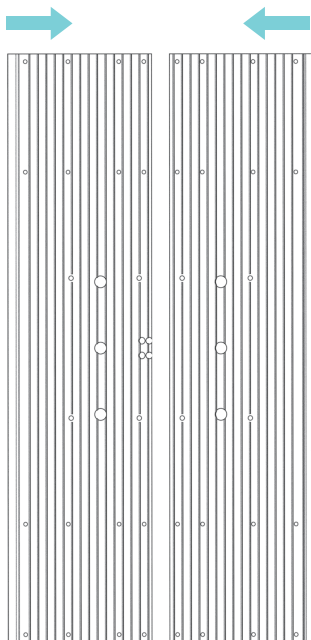

### passo : 2

Bloccare le piastre di rinforzo sotto i pannelli una per una con viti M4 \* 6 da 32 pezzi.

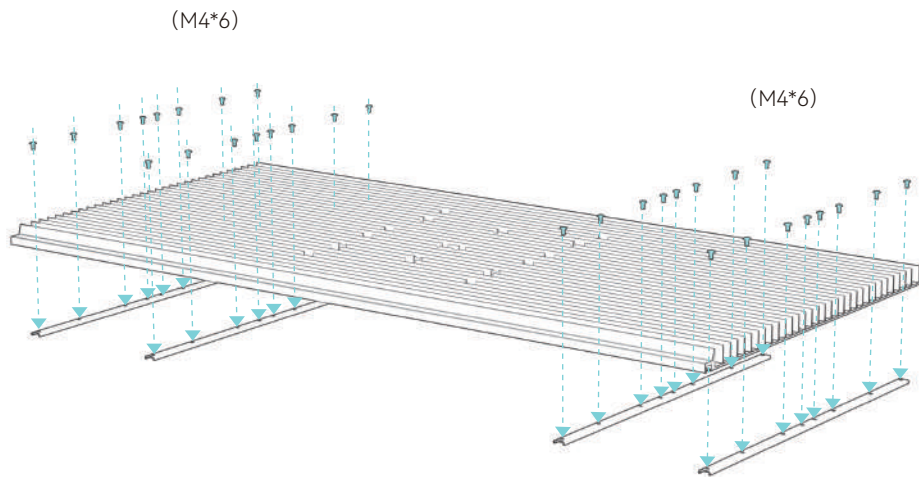

### passo : 3

Installare il pannello assemblato sul componente inferiore con 8 viti M5 \* 10

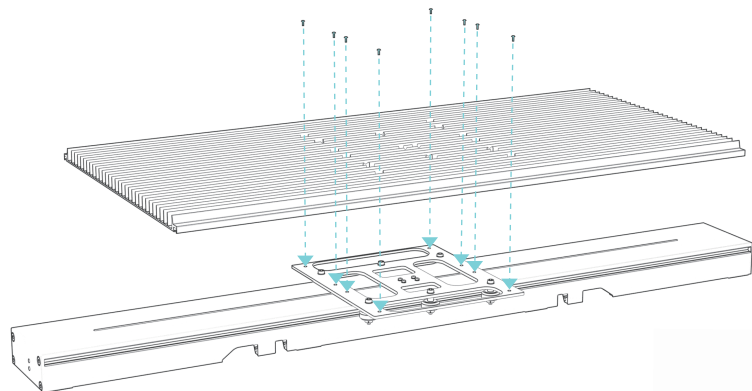

### passo : 4

#### Istruzioni per il fissaggio dei componenti

1) Installare 4 componenti di fissaggio dal bordo del pannello nella direzione mostrata

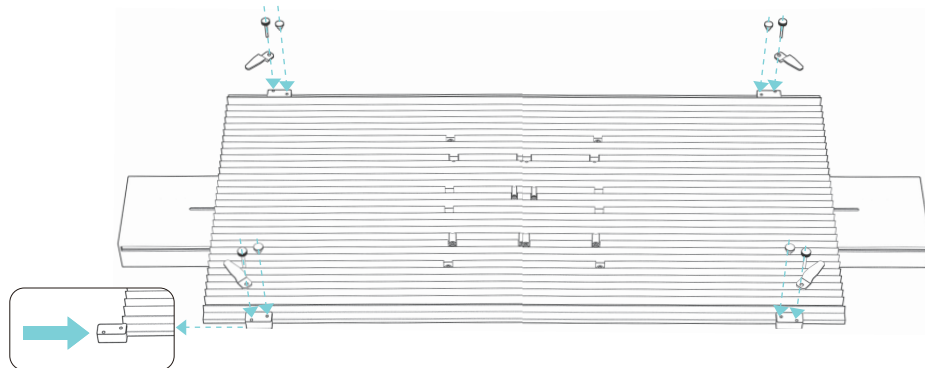



2) Utilizzare direttamente i componenti di fissaggio per l'incisione di oggetti larghi 340-370 mm

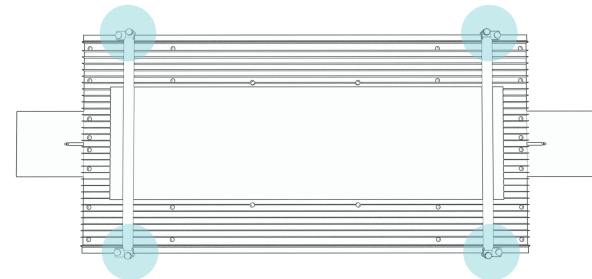
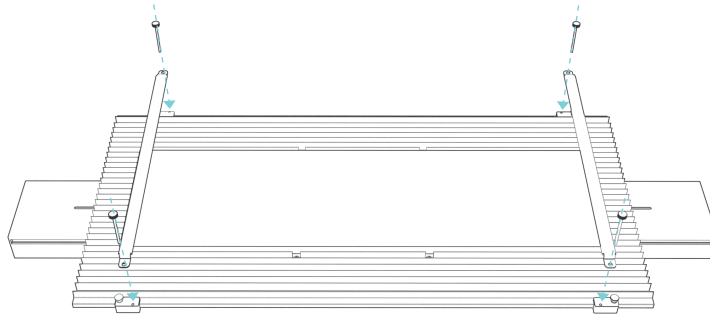

## passo : 5

Allineare il trasportatore verso il basso con i fori e premere direttamente nel supporto del piedino.

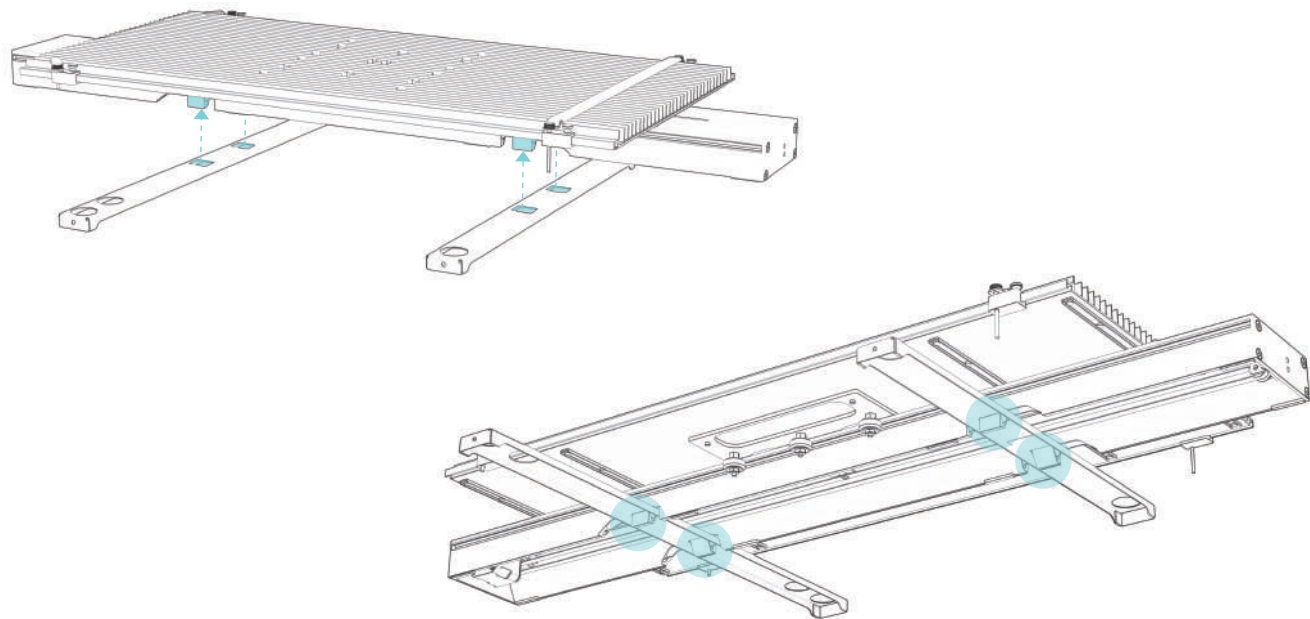

## Utilizzo di piedini di rialzo

### Metodo 1:

Se l'incisore ha riservato i fori per le viti, installare le 4 bretelle come mostrato nelle foto e utilizzate con la staffa di fissaggio del piede.

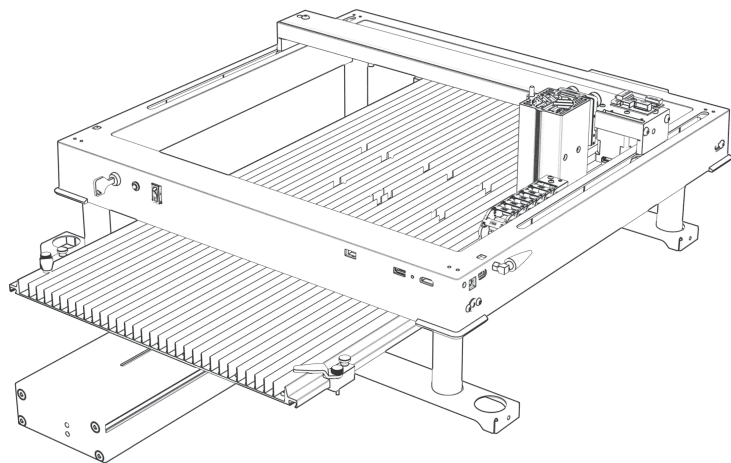

### Metodo 2:

Se i piedini dell'incisore sono pezzi come di seguito, installare come mostrato nella foto e utilizzare con la staffa di fissaggio del piede.

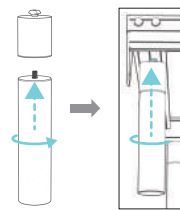

Seguire i passaggi per installare i piedini di elevazione

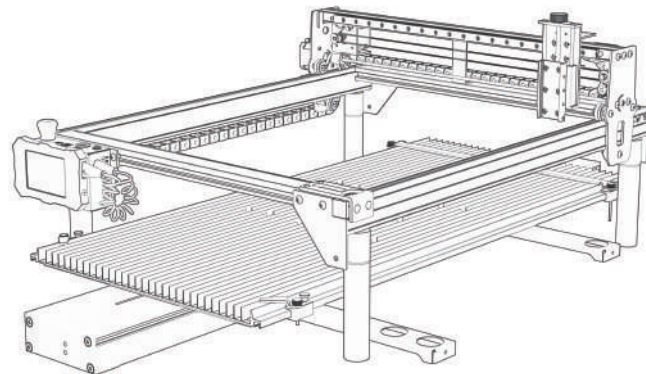



## Collegare il cavo

### Metodo di cablaggio 1: *(Quando la macchina per incidere dispone di una porta di commutazione dell'asse Y)*

1. Individua l'interruttore nell'angolo in basso a destra dell'incisore, scollega il connettore.
2. Estrarre il cablaggio del trasportatore. Interruttore di posizione e porta di commutazione dell'asse Y che collegano il trasportatore e la macchina per incisione.
3. Dopo aver collegato il cavo, capovolgere l'interruttore dell'asse Y verso il basso.

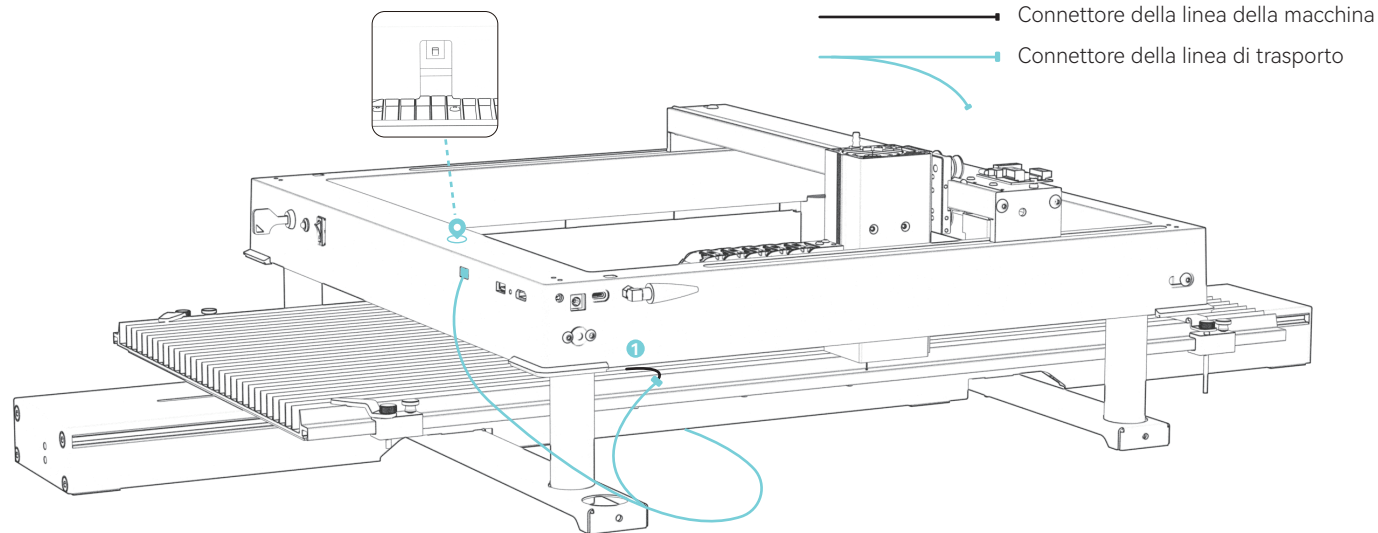

## Metodo di cablaggio 2 : (Quando la macchina per incidere non dispone di una porta di commutazione dell'asse Y)

- 1.Estrarre il cablaggio del trasportatore.
- 2.Scollegare il cablaggio in posizione ❶,Utilizzare un cavo adattatore per collegare alcuni modelli (La macchina per incidere causerà l'inversione del trasportatore. È necessario collegare un'altra linea di conversione di sequenza alla linea del motore).
- 3.Estrarre il filo dal finecorsa e collegarlo ❷

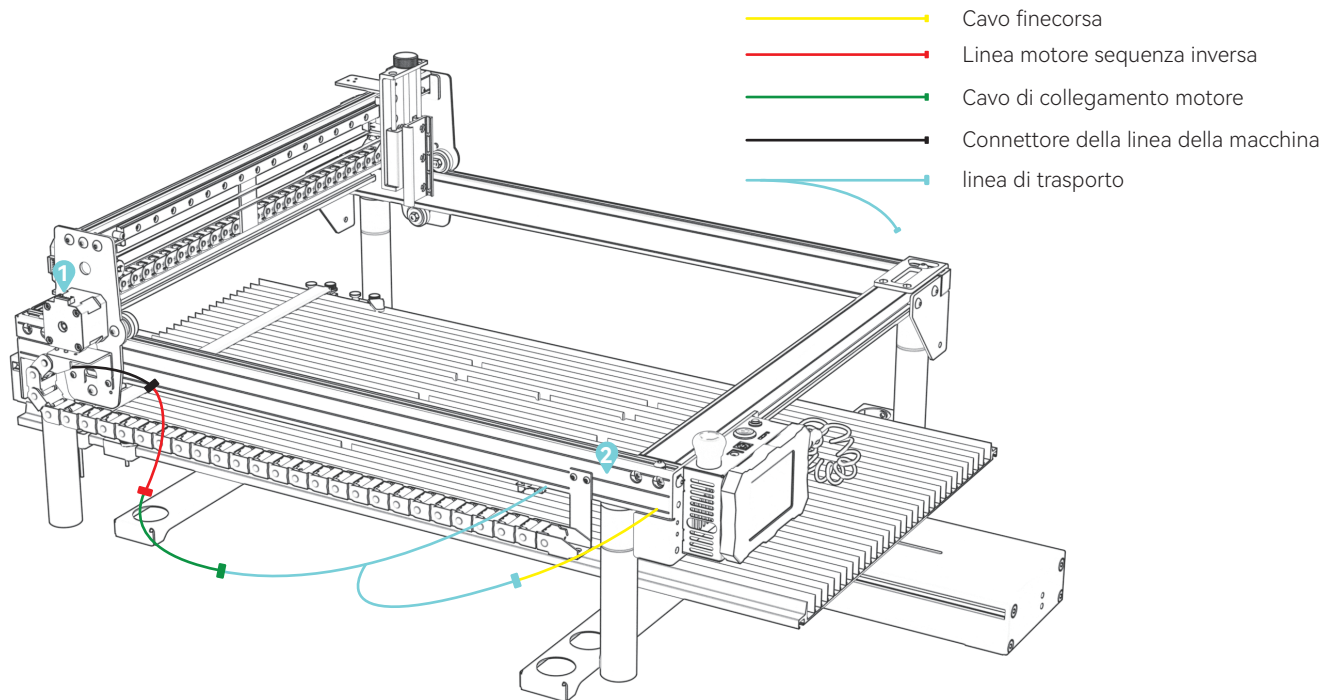

# LaserGRBL modifica il valore massimo della corsa dell'asse Y

(1) Esegui il software LaserGRBL, connettiti all'incisore

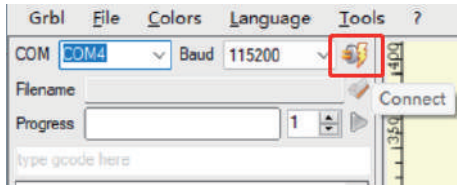

(2) Vai a Configurazione Grbl nel menu Grbl

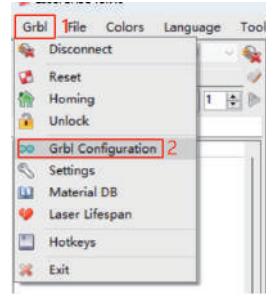

(3) Individua \$ 131, modifica il valore di corsa massima dell'asse Y su 800

\$130	X-axis maximum travel	400.000	millimeters
\$131	Y-axis maximum travel	800.000	millimeters
\$132	Z-axis maximum travel	40.000	millimeters
\$133		300.000	
\$134		300.000	
\$135		300.000	

Refresh Write Export Import

(4) Fai clic su Scrivi

\$130	X-axis maximum travel	400.000	millimeters
\$131	Y-axis maximum travel	800.000	millimeters
\$132	Z-axis maximum travel	40.000	millimeters
\$133		300.000	
\$134		300.000	
\$135		300.000	

Refresh Write Export Import

(5) Chiudere la finestra al termine della modifica

\$130	X-axis maximum travel	400.000	millimeters	Maximum X-axis travel distance from hom...
\$131	Y-axis maximum travel	800.000	millimeters	Maximum Y-axis travel distance from hom...
\$132	Z-axis maximum travel	40.000	millimeters	Maximum Z-axis travel distance from hom...
\$133		300.000		
\$134		300.000		
\$135		300.000		

Refresh Write Export Import Close

(6) Note: Quando il trasportatore non è in uso, il valore di \$ 131 deve essere modificato per tornare al valore predefinito

# LightBurn modify Y-axis maximum travel value

1.Run LightBurn, connect to engraver, “Ready” displayed at 2 indicates connection succeed

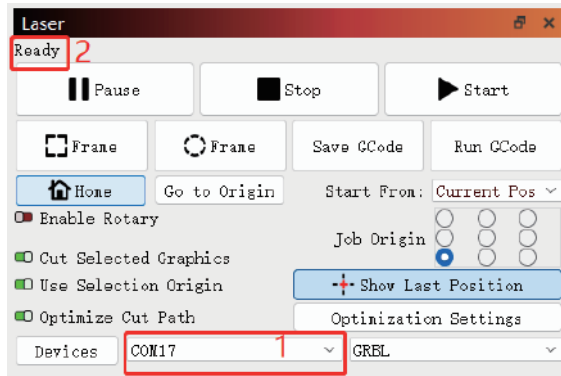

2.Go to Machine Settings under Edit menu

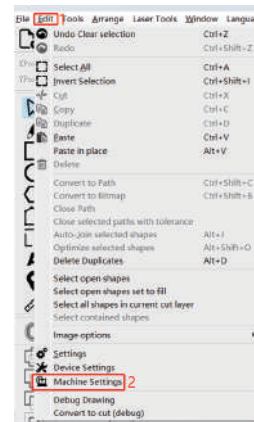

3.Expand output, locate Y max travel(m-m)(\$131), modify the value to 800, click Write then OK to finish

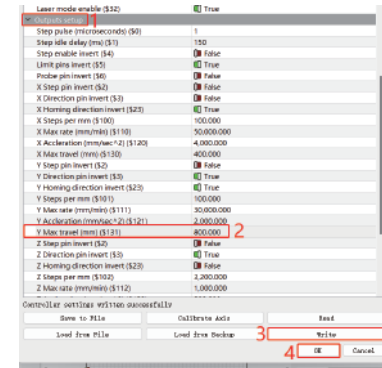

(4)Notes: When the conveyor is not in use, \$131 value needs to be modified back to default value



### **Servizio clienti :**

Per una politica di garanzia dettagliata, visitare il nostro sito Web ufficiale: [www.atomstack.com](http://www.atomstack.com)

Per supporto tecnico e assistenza, inviare un'e-mail : [support@atomstack.com](mailto:support@atomstack.com)

### **Fabbricante :**

Shenzhen atomstack Technologies Co., Ltd.

### **Indirizzo:**

17° piano, edificio 3A, fase II, parco intelligente, n. 76, Baohe Avenue, Baolong Street, distretto di Longgang, Shenzhen, Guangdong, Cina

**CAP:** 518172

### **Scansiona il codice QR :**

Scansione con lettore di codici QR/scanner di codici a barre o qualsiasi app con scanner



**ATOMSTACK**

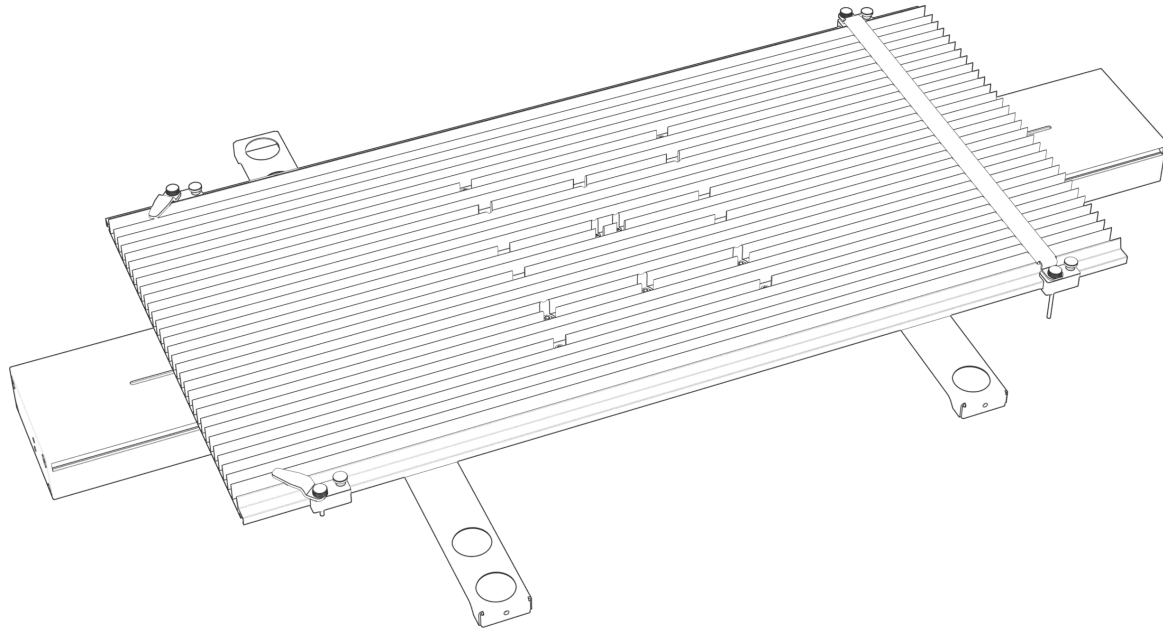

## **R5 Conveyor Manual del usuario**

## Renuncia

Este producto no es un juguete y no es apto para menores de 15 años.

Este producto es un transportador, visite <http://www.atomstack.com/> para obtener el "manual del usuario" completo y las últimas instrucciones y advertencias. AtomStack se reserva el derecho de actualizar este Descargo de responsabilidad y las Pautas de operación segura.

Asegúrese de leer detenidamente este documento antes de utilizar el producto para comprender sus derechos legales, responsabilidades e instrucciones de seguridad; De lo contrario, puede traer pérdidas de propiedad, accidentes de seguridad y peligros ocultos para la seguridad personal. Una vez que utilice este producto, se considerará que ha entendido y aceptado todos los términos y contenidos de este documento. El Usuario se compromete a ser responsable de sus actos y de todas las consecuencias que de ellos se deriven. El Usuario acepta utilizar el Producto solo para fines legítimos y acepta todos los términos y contenidos de este documento y cualquier política o pauta relevante que AtomStack pueda establecer. Usted comprende y acepta que es posible que AtomStack no pueda proporcionarle la causa del daño o accidente y brindarle el servicio posventa de AtomStack a menos que proporcione los archivos originales de grabado o corte, los parámetros de configuración del software de grabado utilizados, la información del sistema operativo, el video del proceso de grabado o corte y los pasos operativos antes de que ocurra un problema o falla.

AtomStack no es responsable de todas y cada una de las pérdidas que surjan de la falta de uso del producto por parte del usuario de acuerdo con este manual.

AtomStack tiene el derecho final de interpretar el documento, sujeto al cumplimiento legal. AtomStack se reserva el derecho de actualizar, modificar o rescindir los Términos sin previo aviso.

## Declaración

La función de grabado requiere LightBurn para controlarla, descargue la versión oficial del software LightBurn. LightBurn es un software de terceros, por lo que el servicio ATOMSTACK no es responsable de ninguna pérdida causada por el funcionamiento de LightBurn, el firmware de ATOMSTACK ha sido probado en detalle por ATOMSTACK y aún puede ocurrir incompatibilidad con el software o hardware. Si se produce un error debido a la incompatibilidad, puede ponerse en contacto con nuestro departamento de atención al cliente para obtener support.- [support@atomstack.com](mailto:support@atomstack.com) técnico

# Lista de empaque

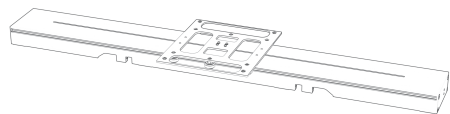

Componente inferior



Patas de elevación roscadas 1



Patas de elevación roscadas 2

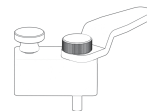

Componente de fijación 4pcs



Cepillo



M4\*6 (32pcs)

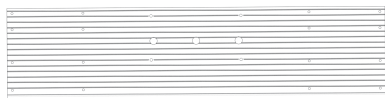

Panel lateral izquierdo



Tornillo de cabeza moleteada 4pcs



Base de apoyo para los pies elevada (larga)



M5\*6 (8pcs)



Paneles laterales derechos

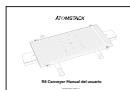

Manual de usuario



Base de apoyo para los pies elevada (corta)



Placa de refuerzo 4pcs



Llave hexagonal H2.5, H3



Cable de motor de secuencia inversa



Cable de conexión del motor del transportador



Pieza de fijación (larga) 2PCS



## Pasos de instalación

### paso : 1

Alinee el panel lateral izquierdo y el panel lateral derecho

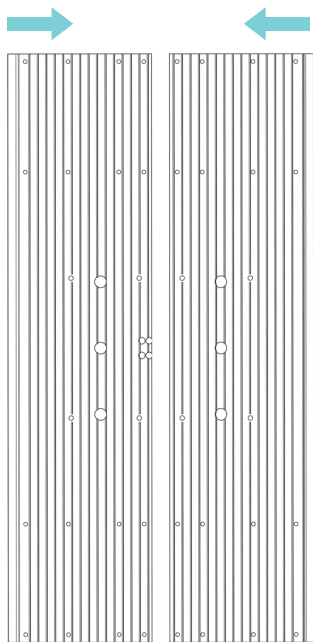

### paso : 2

Bloquee las placas de refuerzo debajo de los paneles una por una con 32 tornillos M4\*6.

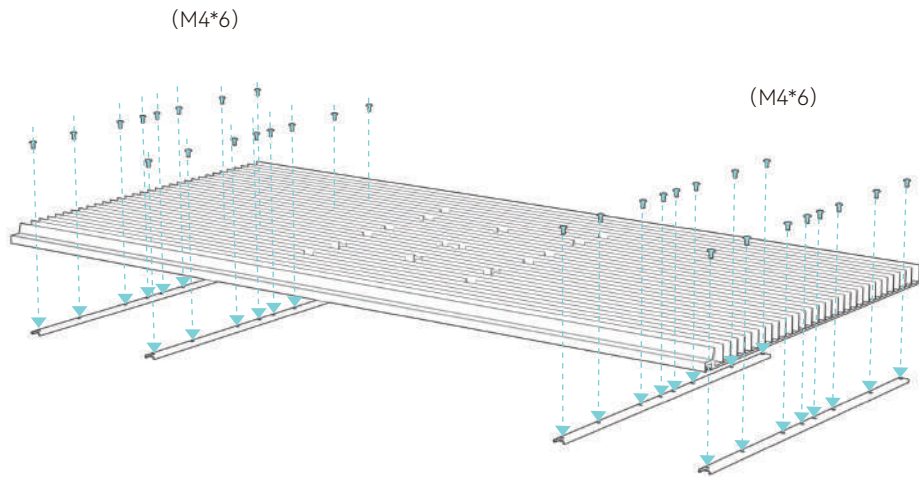

### passo : 3

Instale el panel ensamblado en el componente inferior con 8 tornillos M5 \* 10

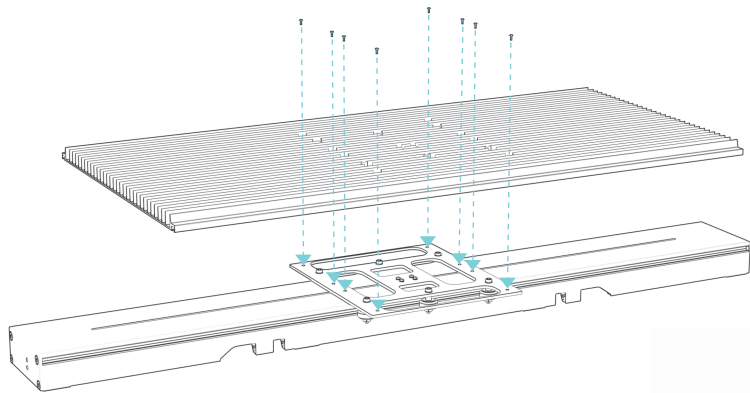

### passo : 4

#### Instrucciones de fijación de componentes

1) Instale 4 componentes de fijación desde el borde del panel en la dirección que se muestra

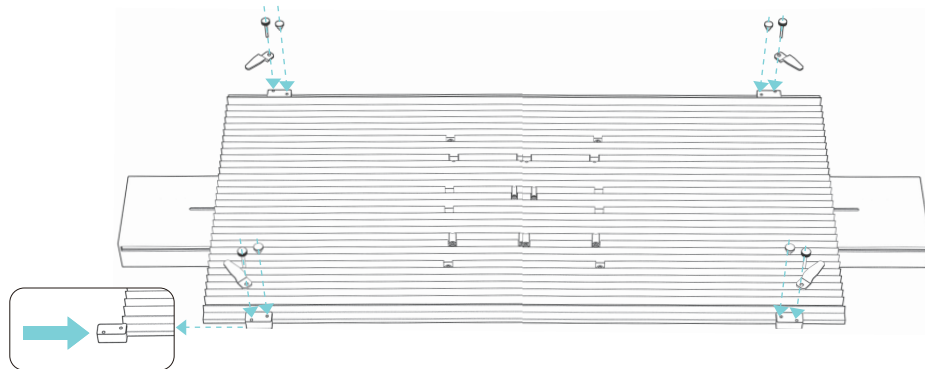



2) Utilice los componentes de fijación directamente al grabar objetos de 340-370 mm de ancho

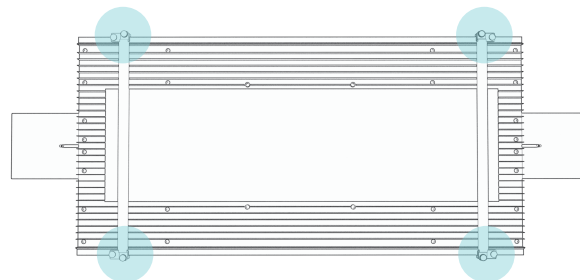
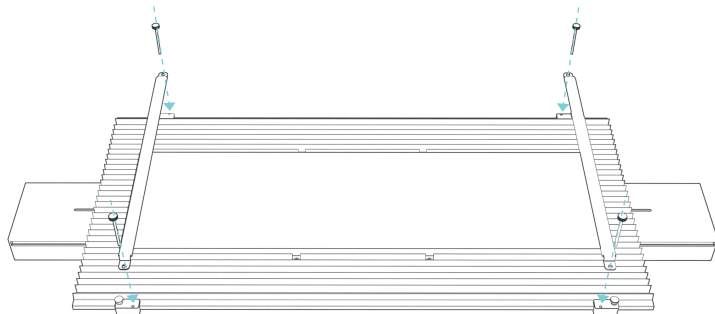

## passo : 5

Alinee il trasportador hacia abajo con los orificios y presione directamente en el soporte del pie.

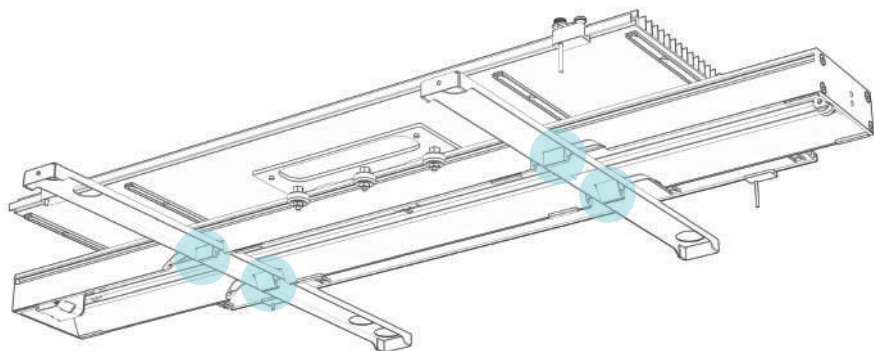
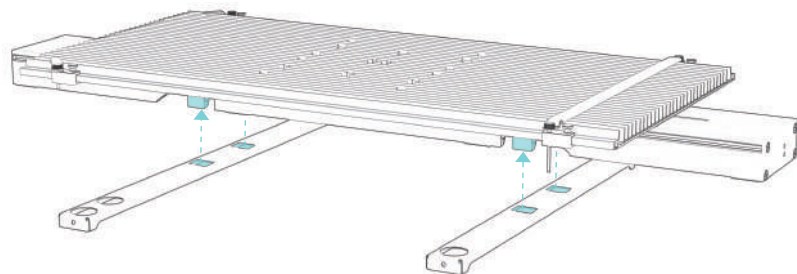

## Uso de pies de elevación

### Método 1:

Si el grabador tiene orificios para tornillos reservados, instale los 4 elevadores como se muestra en las fotos, y utilícelos con el soporte de fijación del pie.

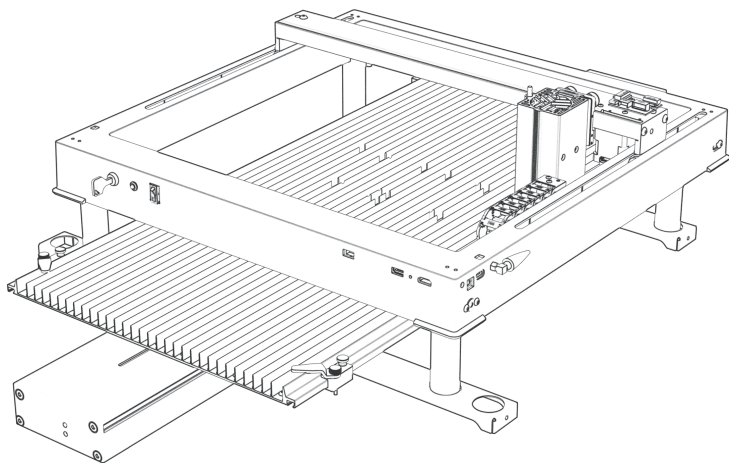

### Método 2:

Si los pies del grabador son piezas como las que se muestran a continuación, instálasas como se muestra en la foto y utilícelas con el soporte de fijación del pie.

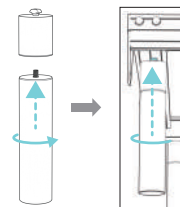

Siga los pasos para instalar los pies de elevación

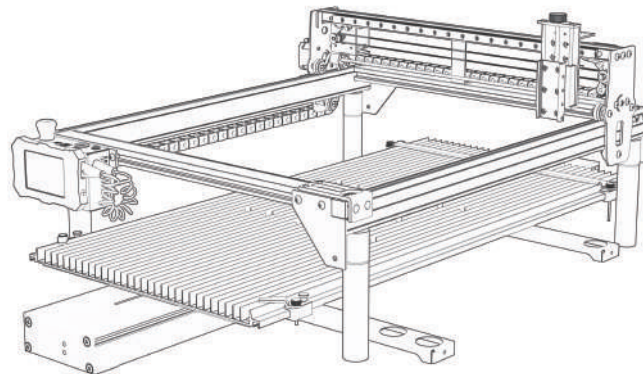

## Conecte el cable

### Método de cableado 1: (Cuando su máquina de grabado tiene un puerto de conmutación del eje Y)

1. Ubique el interruptor en la esquina inferior derecha del grabador, desenchufe el conector.
2. Saque el arnés del transportador. Interruptor de posición y puerto de conmutación del eje Y que conecta el transportador y la máquina de grabado.
3. Después de enchufar el cable, gire el interruptor del eje Y hacia abajo.

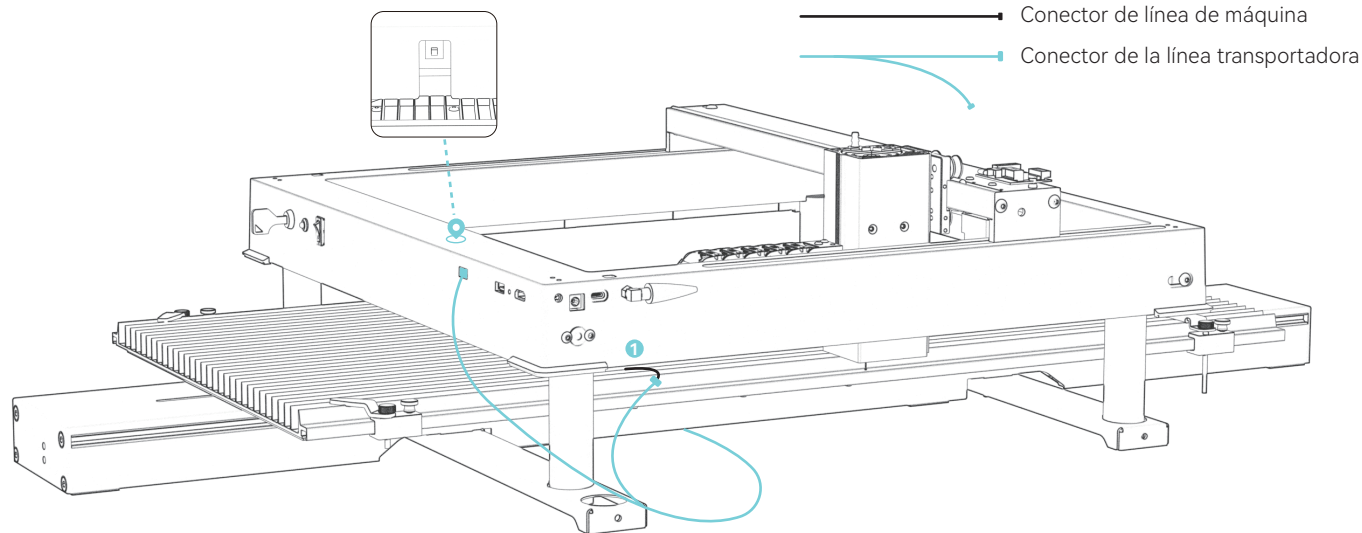

## Método de cableado 2 : (Cuando su máquina de grabado no tiene un puerto de conmutación del eje Y)

1.Saque el arnés del transportador.

2.Desenchufe el cableado en el lugar , Utilice un cable adaptador para conectar ciertos modelos (La máquina de grabado hará que el transportador se invierta. Es necesario conectar otra línea de conversión de secuencia a la línea del motor).

3.Saque el cable en el interruptor de límite y conéctelo 

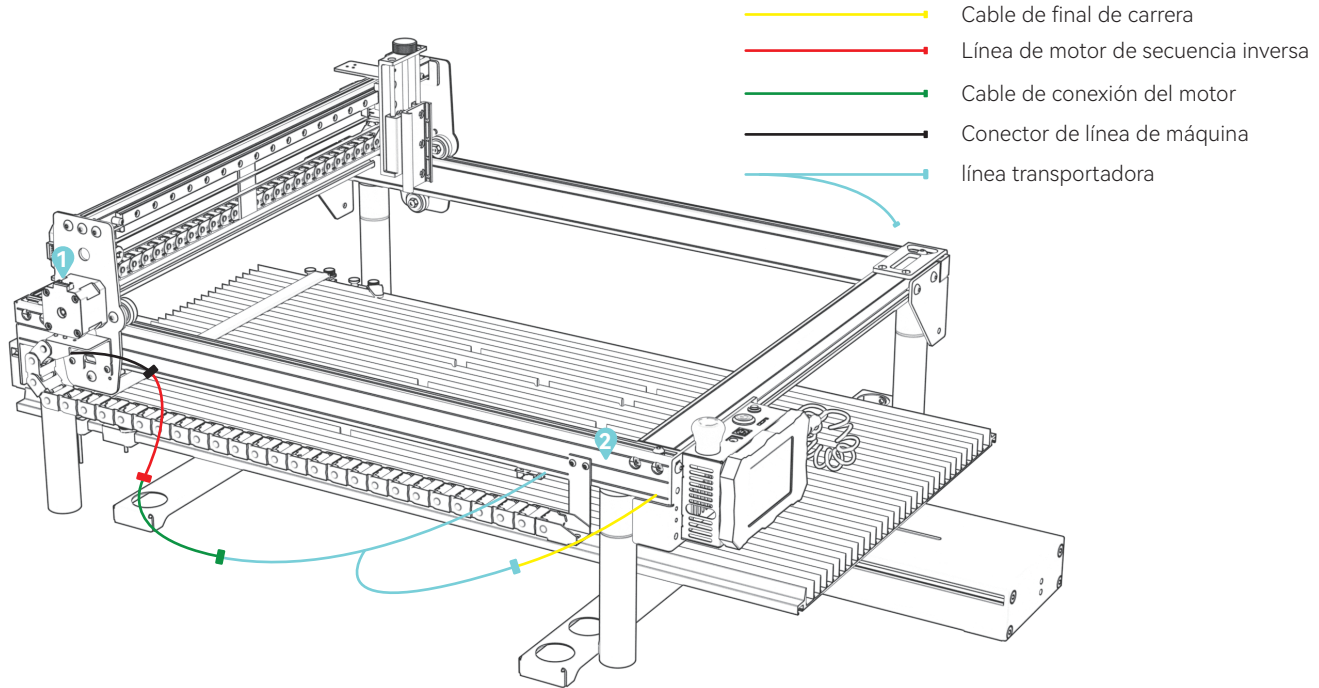

# LaserGRBL modifica el valor máximo de recorrido del eje Y

(1) Ejecute el software LaserGRBL, conéctese al grabador

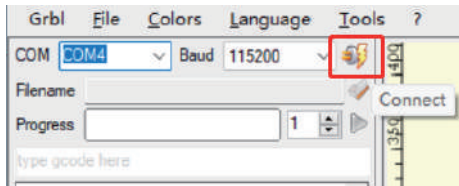

(2) Vaya a Configuración de Grbl en el menú Grbl

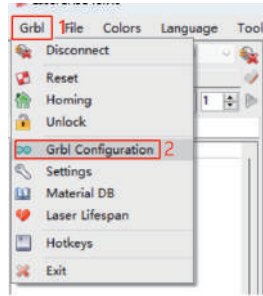

(3) Localice #131, modifique el valor máximo de recorrido del eje Y a 800

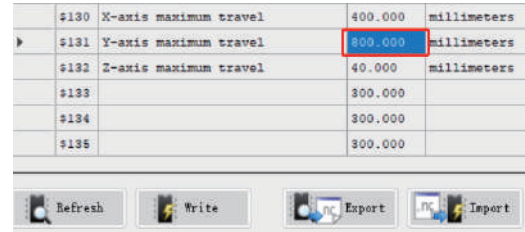

(4) Haga clic en Escribir

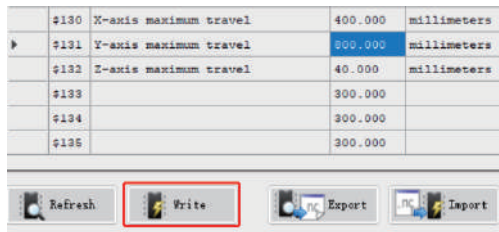

(5) Cierre la ventana una vez completada la modificación

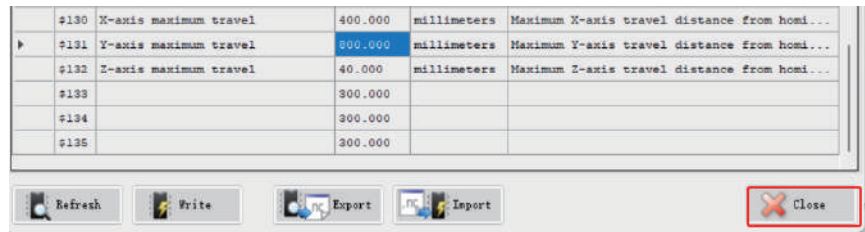

(6) Notas: Cuando el transportador no está en uso, el valor de #131 debe modificarse de nuevo al valor predeterminado



# LightBurn modifica el valor máximo de recorrido del eje Y

1. Ejecute LightBurn, conéctese al grabador, "Listo" que se muestra en 2 indica que la conexión se realizó correctamente

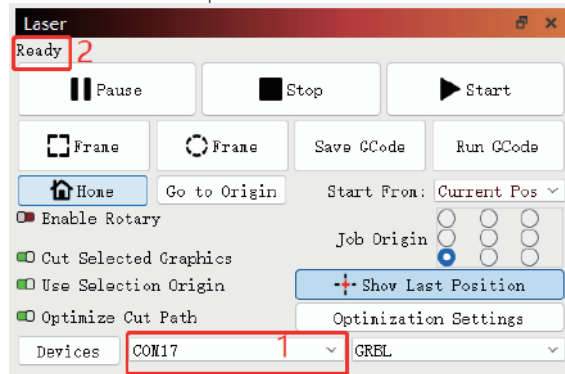

2. Vaya a Configuración de la máquina en Editar menú

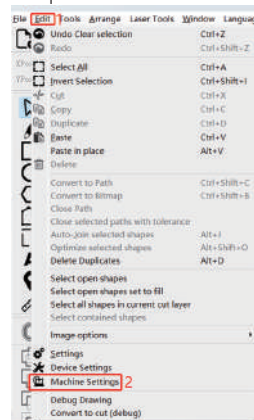

3. Expanda la salida, localice Y recorrido máximo (mm) (\$131), modifique el valor a 800, haga clic en Escribir y luego en Aceptar para finalizar

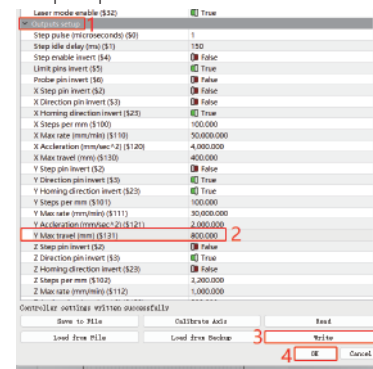

(4) Notas: Cuando el transportador no está en uso, el valor de \$131 debe modificarse de nuevo al valor predeterminado



### **Servicio al cliente :**

Para conocer la política de garantía detallada, visite nuestro sitio web oficial: [www.atomstack.com](http://www.atomstack.com)

Para soporte técnico y servicio, envíe un correo electrónico : [support@atomstack.com](mailto:support@atomstack.com)

### **Fabricante:**

Shenzhen atomstack Technologies Co., Ltd.

### **Dirección:**

Piso 17, Edificio 3A, Fase II, Parque Inteligente, No. 76, Avenida Baohe, Calle Baolong,  
Distrito de Longgang, Shenzhen, Guangdong, China

**Código postal:** 518172

### **Escanear código QR :**

Escanee con lector de códigos QR/escáner de código de barras o cualquier aplicación con escáner



# ATOMSTACK

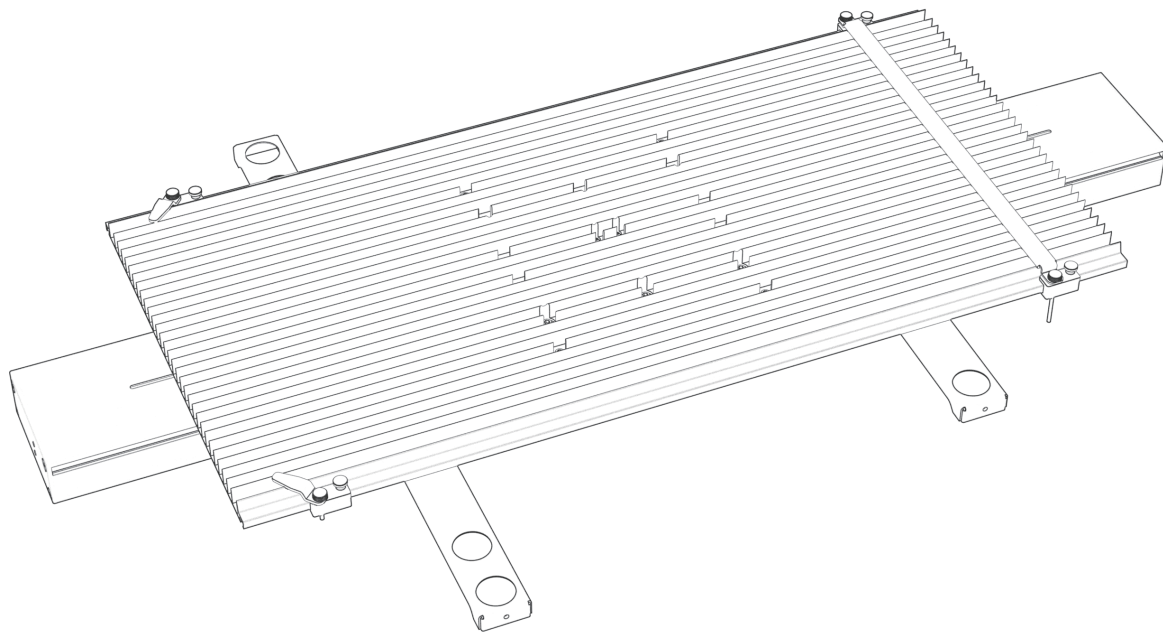

## R5传送带 用户说明书

# 免责声明

本产品不是玩具，不适合 15 岁以下人士使用。

本产品是传送带，请访问 <http://www.atomstack.com/> 以获取完整的“用户手册”以及最新的说明和警告。AtomStack 保留更新本免责声明和安全操作指南的权利。

请务必在使用产品前仔细阅读本文档，了解您的合法权利、责任和安全说明；否则，可能会带来财产损失、安全事故和人身安全隐患。一旦您使用本产品，即视为您已理解并接受本文档的所有条款和内容。用户承诺对其自己的行为以及由此产生的所有后果负责。用户同意仅将产品用于合法目的，并同意本文档的所有条款和内容以及 AtomStack 可能制定的任何相关政策或指南。您理解并同意，除非您提供原始的雕刻或切割文件、使用的雕刻软件配置参数、操作系统信息、雕刻或切割过程的视频，以及出现问题或故障之前的操作步骤。

对于因用户未能按照本手册使用产品而造成的任何及所有损失，AtomStack 不承担任何责任。

AtomStack 拥有解释本文档的最终权利，但须遵守法律规定。AtomStack 保留更新、修改或终止条款的权利，恕不另行通知。

# 声明

雕刻功能需要LightBurn控制，请下载官方版LightBurn软件。LightBurn是第三方软件，因此ATOMSTACK服务不对LightBurn运行造成的任何损失负责，ATOMSTACK的固件已经过ATOMSTACK详细测试，仍然可能会出现软件或硬件不兼容的情况。如果因不兼容而出现错误，您可以联系我们的客服部门获取技术支持。support@atomstack.com

# 产品清单

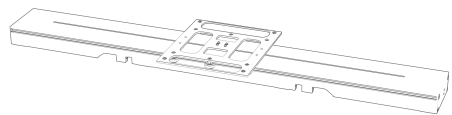

底部组件



增高脚 1



螺纹式增高脚 2

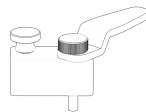

固定组件4pcs



Brush



M4\*6 (32pcs)

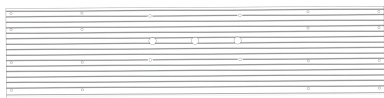

平台左侧板



M4\*50滚花螺丝



增高脚支撑座 (长)



M5\*6 (8pcs)



平台右侧板

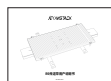

说明书



增高脚支撑座 (短)



平台加强板4pcs



H2.5, H3 内六角扳手



逆序电机线



Y轴电机连接线



固定片 (长) 2PCS

## 机器安装步骤

### 步骤一

把平台左侧板和平台右侧板并排拼齐

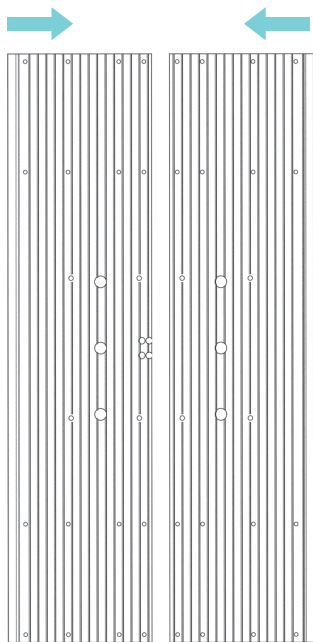

### 步骤二

把平台加强板依次在平台板下方并依次锁入 32 颗 M4\*6。

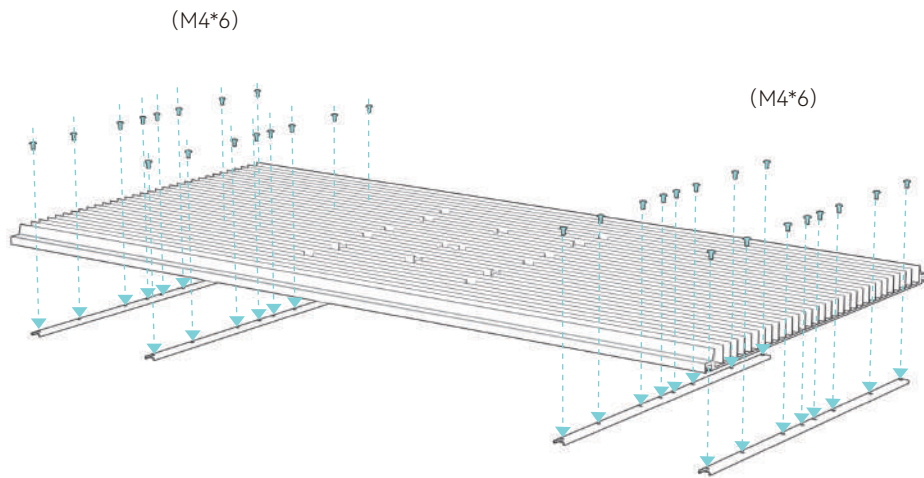

### 步骤三

把平台安装在底座上并锁入8颗M5\*10螺丝。

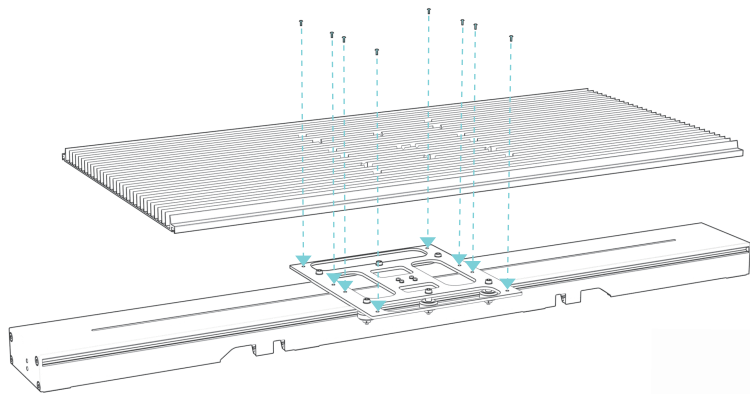

### 步骤四

#### 固定组件使用说明

1) 如果雕刻340mm-370mm宽度的材料则直接使用固定组件。将零件滑入传送带，用螺丝沿如图方向装入其他固定组件。

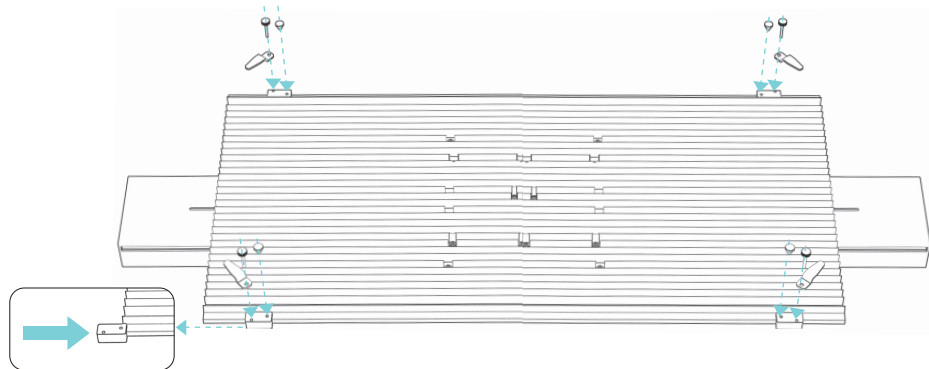



2) 如果雕刻宽度过小的材料则拧下固定组件的滚花螺丝并更换成M4\*50滚花螺丝且同时安装上固定片。

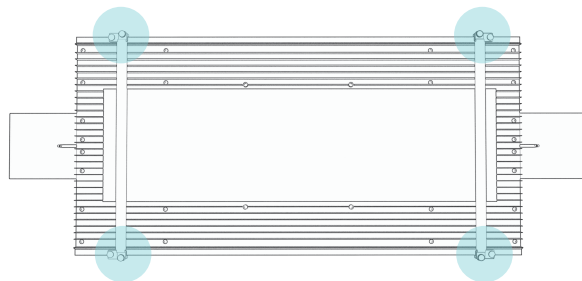



## 步骤五

将传送带向下对准孔位直接压入脚固定架。

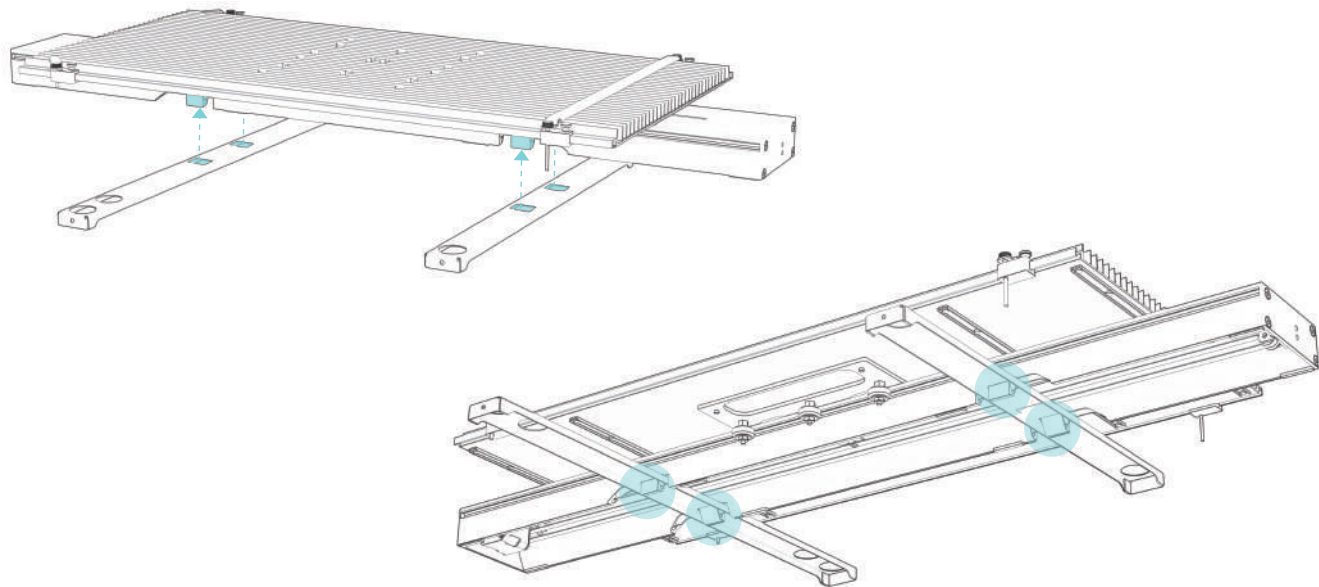

## 增高脚的使用方法

### 方法一：

如果顾客使用的雕刻机有预留螺丝孔  
则如图使用4个增高脚。并配合脚固定架使用。

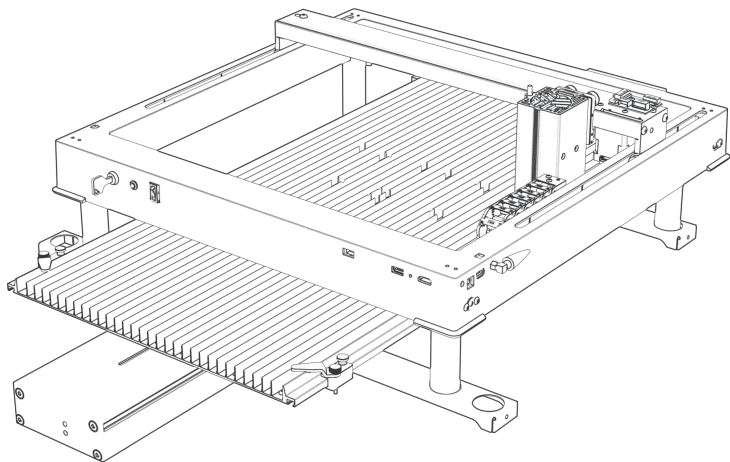

### 方法二：

如果顾客使用的雕刻机是铝片形状的支撑脚  
则如图使用4个增高脚，并配合脚固定架使用。

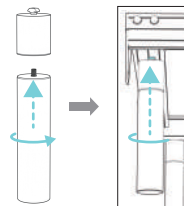

按步骤安装增高脚

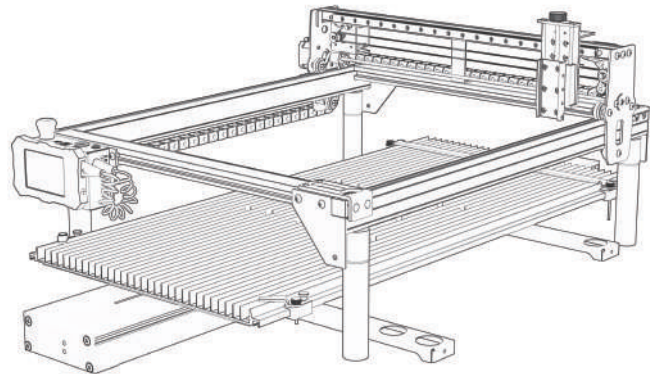

## 接线

### 接线方式一：（当您的雕刻机有Y轴切换口时）

1. 找到雕刻机右下角的1位置开关接口，拔下插件。
2. 拉出传送带的线束。连接传送带和雕刻机的位置开关和Y轴切换口
3. 插完线后向下拨动Y轴切换开关。

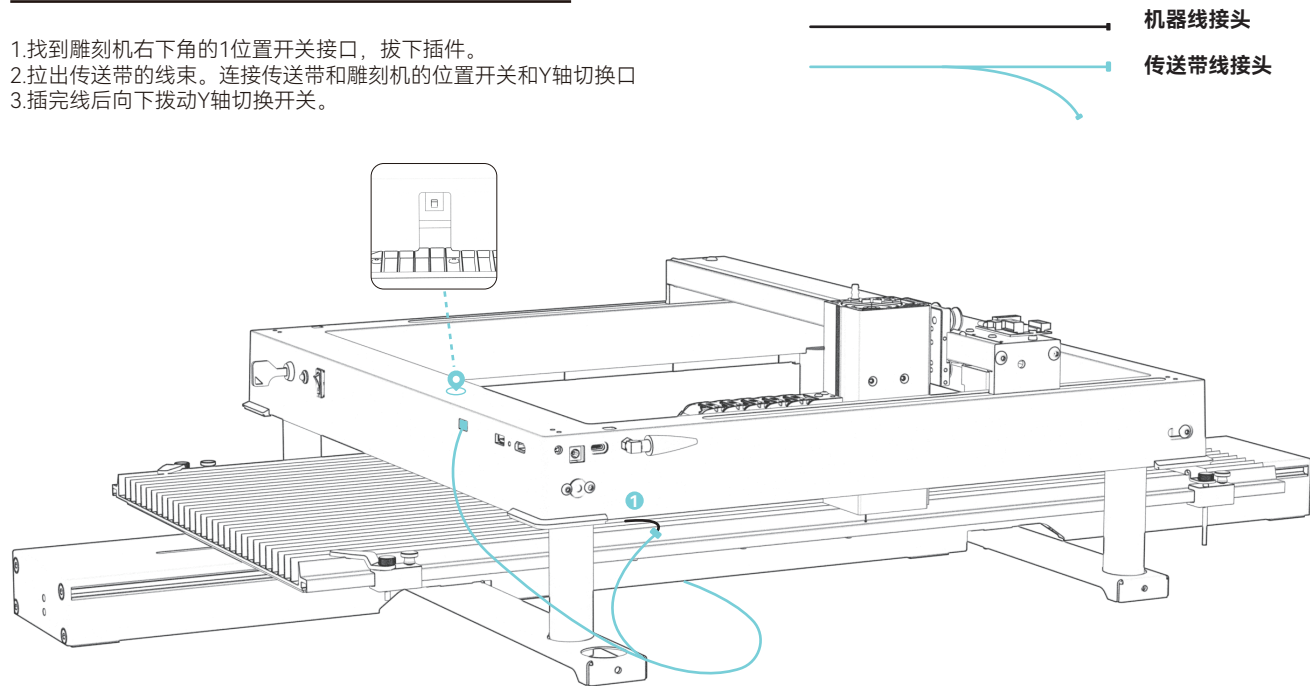

## 接线方式二：（当您的雕刻机没有Y轴切换口时）

1. 拉出传送带的线束。
2. 拔出 ① 位置的接线，用转接线与相连个别型号(雕刻机会出现传送带反向现象，需在电机线里再接一根顺序转换线)。
3. 拔出限位开关处的线 ②，与其相连

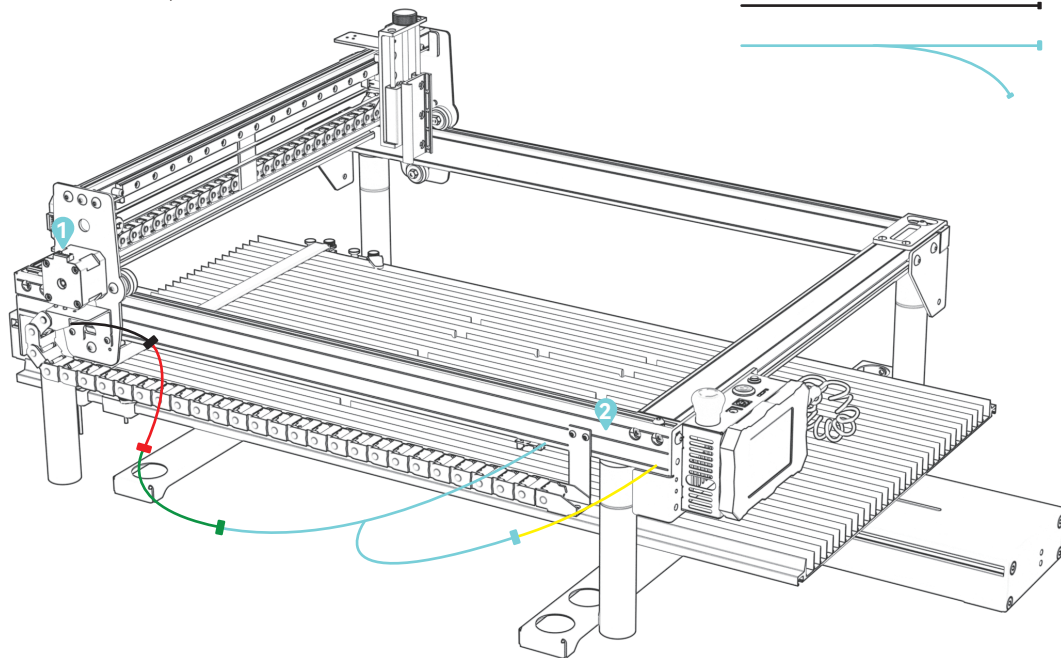

- 限位开关线
- 逆序电机线
- 电机链接线
- 机器线接头
- 传送带线

## LaserGRBL修改Y轴行程参数

(1)打开LaserGRBL软件，并连接到雕刻机。

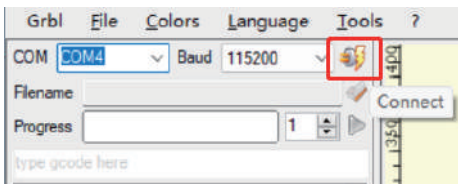

(2)展开Grbl，选择Grbl配置。

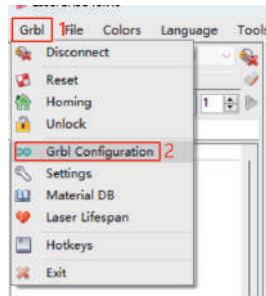

(3)找到项目\$131，并修改原始的y轴最大行程值改为800。

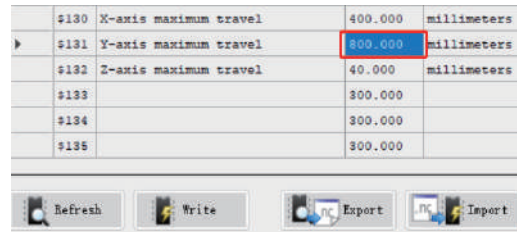

\$130	X-axis maximum travel	400.000	millimeters
\$131	Y-axis maximum travel	400.000	millimeters
\$132	Z-axis maximum travel	40.000	millimeters
\$133		300.000	
\$134		300.000	
\$135		300.000	

(4)单击“写入”

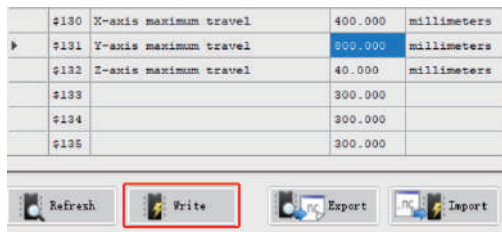

(5)当修改完成后，请关闭该窗口

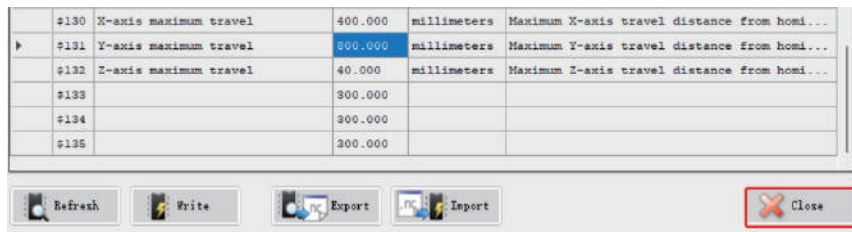

# LightBurn修改Y轴行程步骤

1.打开LightBurn，连接串口，【2】处显示Ready即连接成功

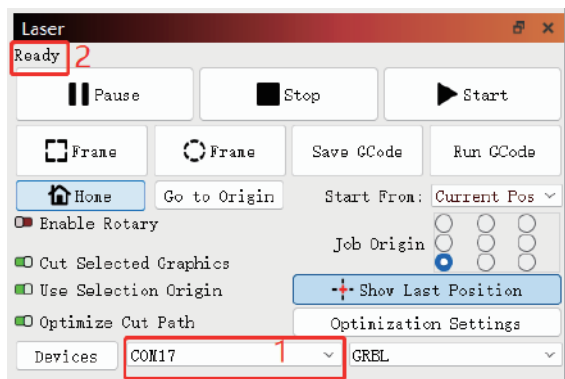

2.点击编辑选择机器设置

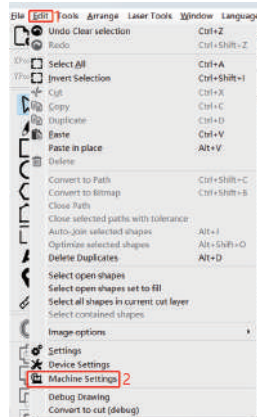

3.打开output设置并找到Y轴最大行程 (mm) (\$131) 并将其改为800, 点击Write, 最后点击OK完成设置

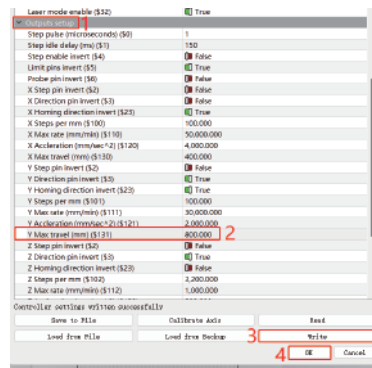

(4)注意：当不使用传送带时，需要把Y轴最大行程改未默认值，即\$131改为默认值



**客户服务：**

详细保修政策请访问我们的官方网站: [www.atomstack.com](http://www.atomstack.com)  
如需技术支持和服务, 请发送电子邮件: [support@atomstack.com](mailto:support@atomstack.com)

**制造商:**

深圳原子智造科技有限公司

**地址:**

广东省深圳市龙岗区宝龙街道宝和大道76号智慧家园二期3A栋17楼

**邮政编码:** 518172

**扫描二维码：**

用QR 码阅读器/条形码扫描仪或任何带有扫描仪的应用程序扫描

