

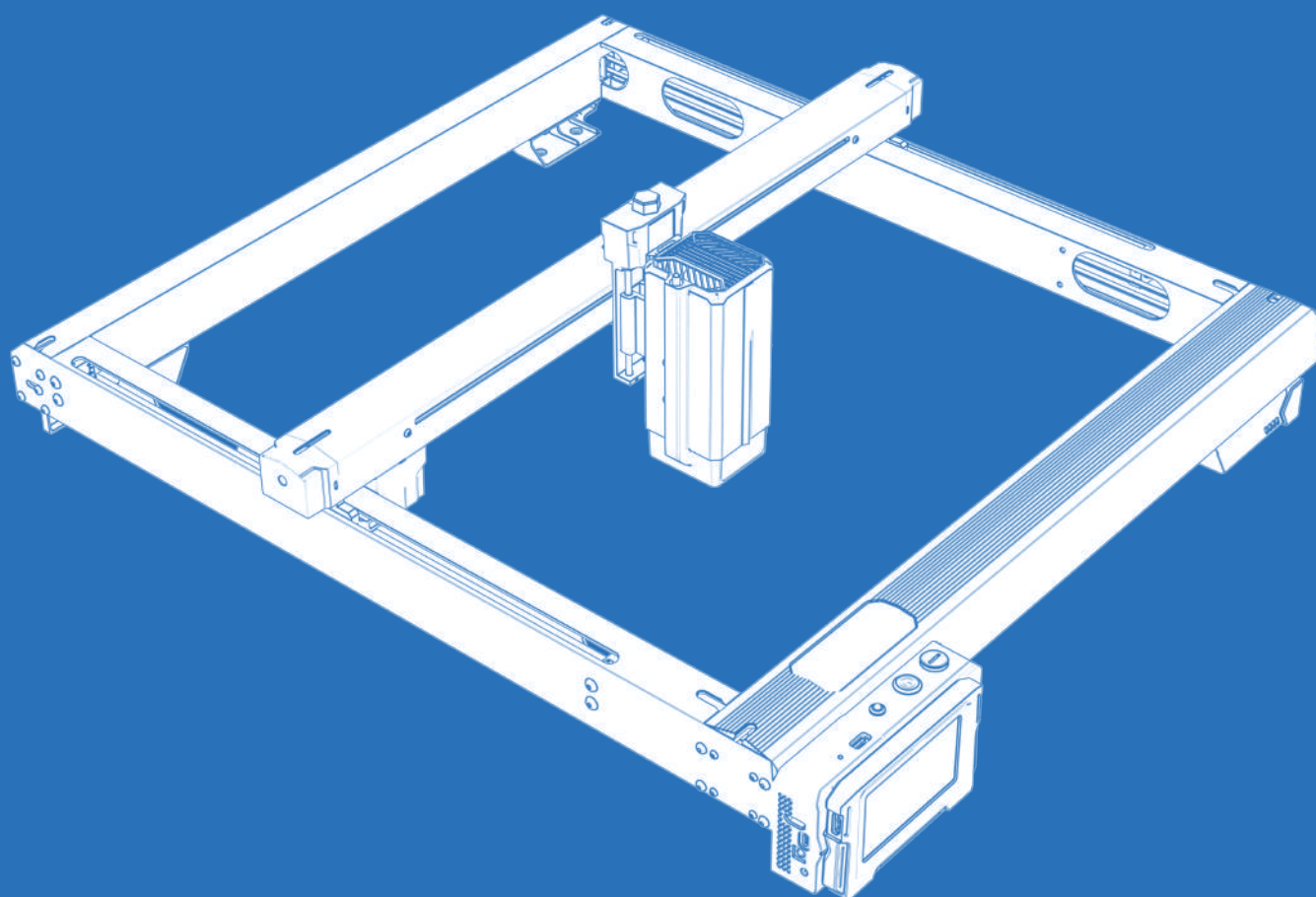

USER MANUAL



IKIER K1 / K1 Pro / K1 Ultra

HOW TO OPERATE THE ENGRAVER MACHINE

1.PC Software :

Mac OS: [LightBurn](#)

Windows: [LightBurn & LaserGRBL](#)



Download LightBurn from below website :
<https://lightburnsoftware.com/download/>



Download LaserGRBL from below website :
<http://lasergrbl.com/download/>

2.Mobile APP :

Download "IKIER" App from
the Apple and Android app stores



3.Offline:

Use with K1 touch screen controller
Read the following instructions for use



LOCK: Security Lock, It can only be opened with a key

ON/OFF: Power On / Off

ALARM: When the limits touched, flame detected, tiltition detected, the alarm works

USB: Insert USB flash drive to update firmware or run the engraving file offline

RESET: Restart the engraver

HDMI: Connect the touch screen controller to the control board with the HDMI cable

TYPE-C: Connect the control board to PC with the Type C cable, when running files with Lightburn or LaserGRBL

INPUT: The engraver power input

OUTPUT: Output 12V DC power supply for air assist, connect the air assist to the control board with the air assist power cable



Scan QR code for
detail intallation and use instruction



ENGRAVING PART

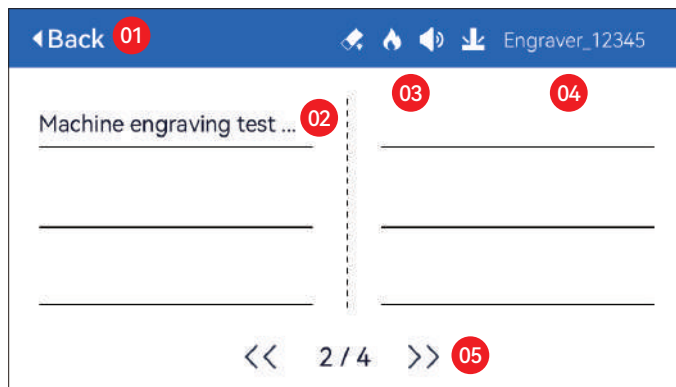

01. Back 02. File Name 03. Status Bar
04. WIFI Name 05. Page Turn Button

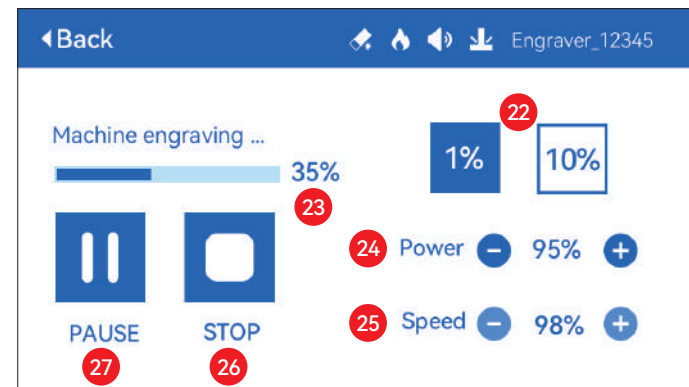

22. Step size adjustment 23. Completion progress
24. Power adjustment 25. Speed adjustment 26. Stop
27. Pause

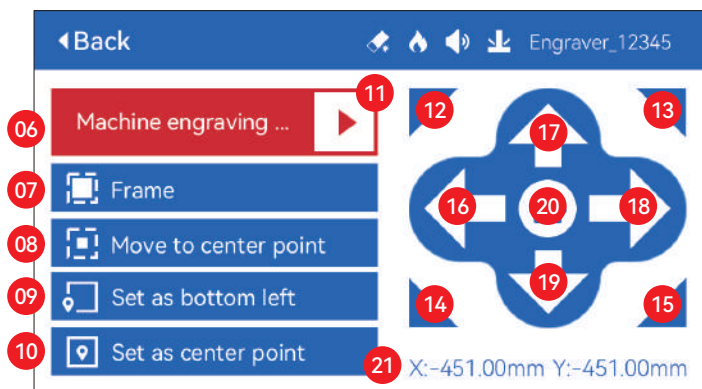

06. File Name
07. Preview border: After clicking this button, the laser module will move around the edge according to the size of the engraved pattern (the cross laser point represents the position of the preview border)
08. Move to center: Click this button, the laser module goes to the center point of the engraved pattern
09. Set bottom left: Set the current position of the laser module as the bottom left initial position
10. Set as center: Set the current position of the laser module as the center point of the pattern
11. Start
12.13.14.15. Click the top-left button, the laser module goes to the upper left corner of the engraved pattern. Same for other buttons.
16.17.18.19. Control the laser module to move up, down, left and right, long press to move continuously
20. Home: The laser module returns to the origin no matter where it is
21. Coordinate values of X-axis and Y-axis

⚙️ SETTING PART

Select Language ▶



Mode ▶



Fast mode: The maximum speed can reach 50000mm/min, ordinary engraving accuracy.

Standard mode: A precision-speed-balanced mode which can be used as a general mode (factory default mode).

Fine mode: Best accuracy, slower speed.

Tilt Detection ▶



Click to enable the function, when the angle between the machine and the horizontal plane $> 15^\circ$, the function is triggered. Machine automatically stops working, prompts "The machine is tilted", and the buzzer sounds. Tap "OK" on the screen to dismiss the alarm.

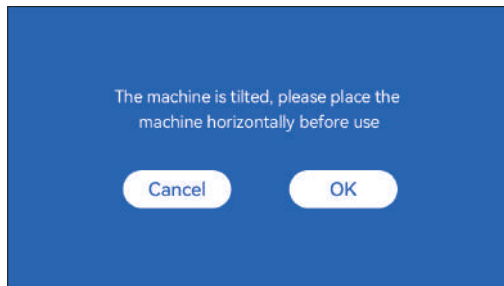

Flame Detection ▶

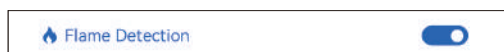

*** Precautions:** Sunlight exposure may cause false triggering of functions, when using the machine outdoor. It is recommended to use it indoors. Click to enable the function. When a fire occurs directly below the laser module, the function will be triggered: the laser module automatically returns to the origin, prompts "Flame detected", and the buzzer sounds. It can be used normally after restarting the machine.

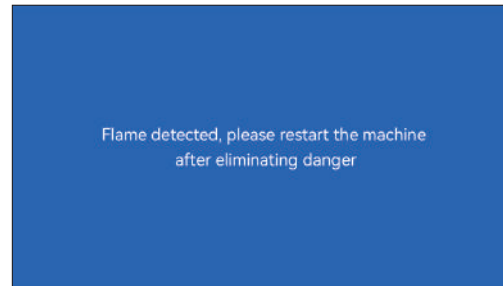

Autofocus ▶



*** Precautions:**

01. When using chuck, roller, or engraving/cutting irregular objects, like pebbles, soft materials such as office paper, kraft paper, cashmere cloth, denim, etc, it is recommended to use a fixed focus block to focus manually;

02. If there is a prompt of exceeding the maximum range, it is necessary to raise the engraved object to ensure that the laser module can touch the object within the effective stroke.

03. Keep a distance of at least 5mm between the laser slider and the base; at the same time, make the laser be in natural contact with the object, tighten the fixing screws to ensure the smooth operation of autofocus.

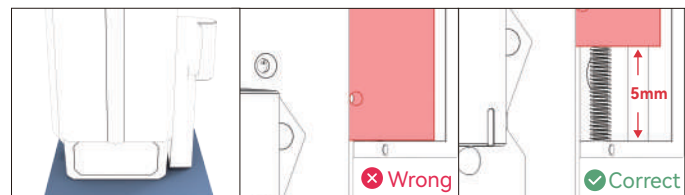

How to use "Autofocus" function with touch screen controller:

01. Turn on the "Autofocus" function
02. Select the engraving file, the machine will automatically start focusing after clicking Start, and start engraving after the focus is completed

(A) How to set "Autofocus" function in LightBurn:

01. Find "Window" in the top navigation bar, and enable "Console" function in the drop-down menu

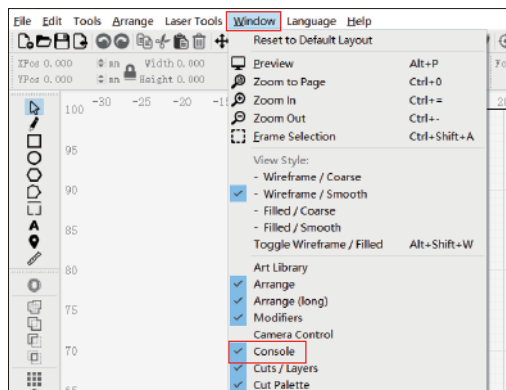

02. Select any custom button, right click mouse to pop up the button setting page, enter the name of the button in "Button Label", enter [ESP500] under "Macro contents"

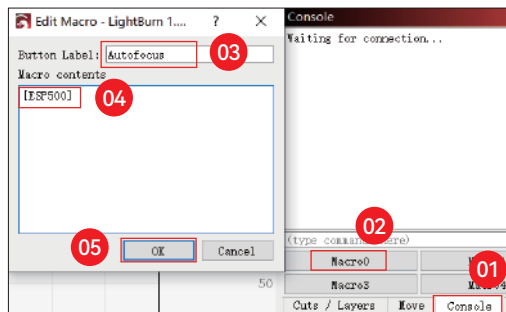

03. After clicking OK, a button with the corresponding function will be generated

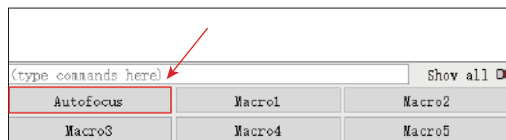

(B) How to set "Autofocus" function in LaserGRBL:

01. In the following toolbar, right click on the blank space to pop up the "Add Custom Button" window, click Add Custom Button

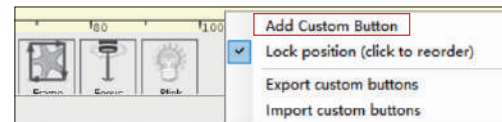

02. Entrez [ESP500] dans "GCode", entrez le nom du bouton dans "Caption" et "Tool Tip", vous pouvez personnaliser l'image du bouton sur la gauche, et cliquez sur "Créer" pour générer un bouton personnalisé avec la fonction correspondante

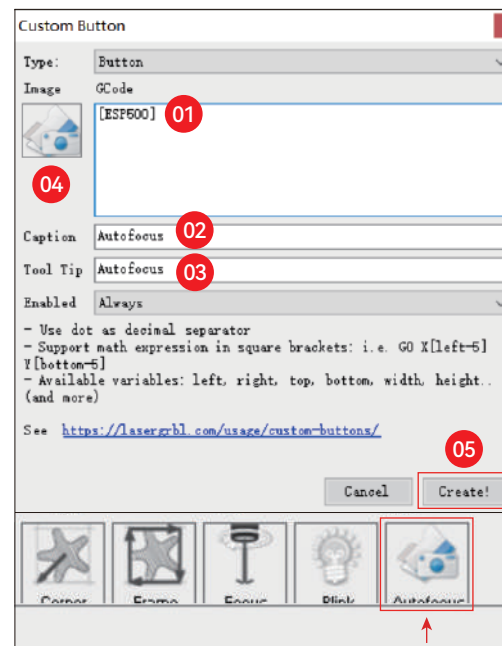

How to use "Autofocus" function in LightBurn and LaserGRBL:

Move the focus point to the top of the engraving object, click the "Autofocus" button just set to start autofocus

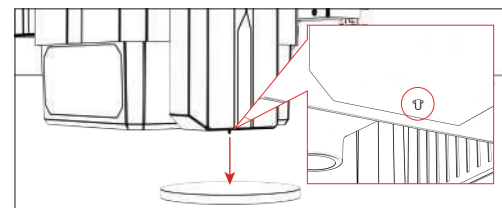

Resume Engraving

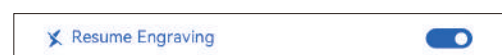

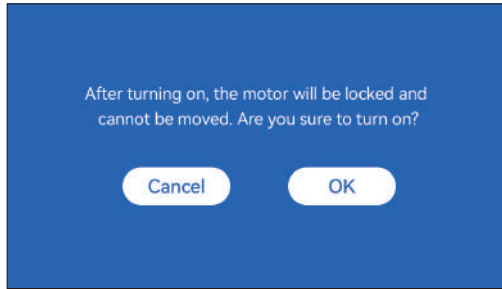

*** Precautions:**

- 01. "Resume engraving" can only be used offline or with mobile APP
- 02. After turning on resume engraving function, the motor will be locked, do not forcefully move the laser module by hand
- 03. Make sure keep the engraving machine and the object to be engraved without displacement after the power is off, otherwise it will cause the engraving to deviate;
- 04. When parsing files during resume engraving, be careful not to plug or unplug the HDMI cable, otherwise you need to restart the machine to achieve the function.
- 05. Make sure that "Auto-home startup" is turned off, otherwise it will affect the normal use of the resume engraving function

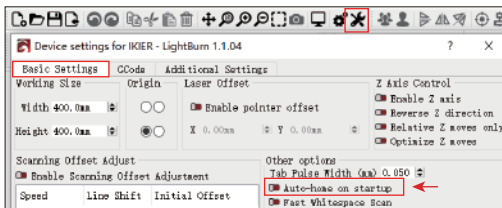

How to use "Resume Engraving" function:

- 01. Select the engraving file.
- 02. Using the touch screen controller to move the laser to the location where the engraving is required
- 03. Click "Set as bottom left", Set the current position as the initial position
- 04. Click "Start", the machine will automatically start engraving after the analysis of the file

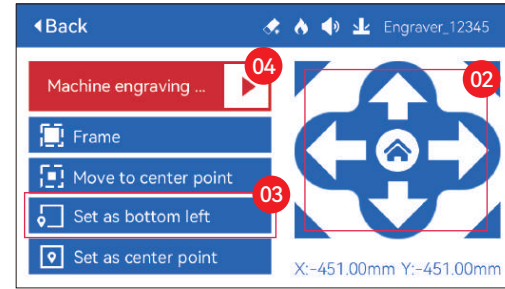

Touch sound



Turn on/off touch sound

Auxiliary positioning

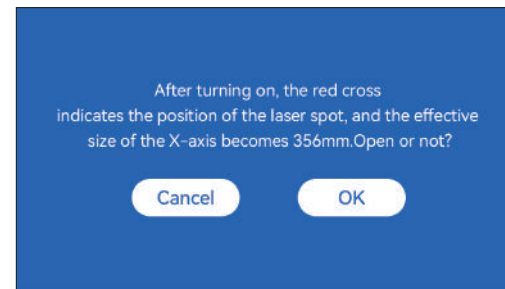

*** Precautions:**

- 01. Do not disassemble the laser module after calibration, otherwise recalibration is required;
- 02. When LightBurn exports the .gc file, you need to select the current position - set the lower left corner as the starting point to accurately position
- 03. After turning on, the red cross laser position represents the focus position of the laser.

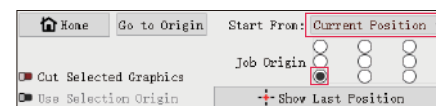

How to calibrate

01. After opening the "Auxiliary positioning" function, click "▶"



02. Click the "Mark current position" button

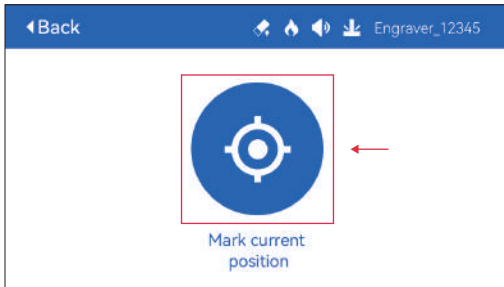

03. Observe the error between the position of the mark and the cross laser, if there is an error, proceed to the next step of calibration

04. Click the up, down, left, and right buttons to move the cross laser light as close as possible to the mark position (error value <1mm), and click "CONFIRM" after calibration

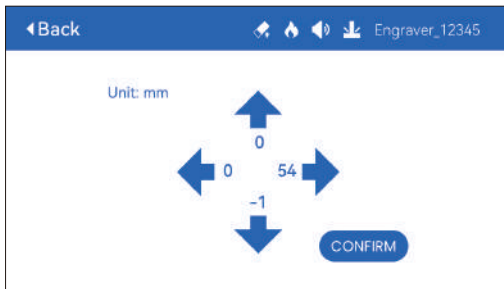

(A) How to set "Auxiliary positioning" function in LightBurn:

01. Find "Window" in the top navigation bar, and enable "Console" function in the drop-down menu

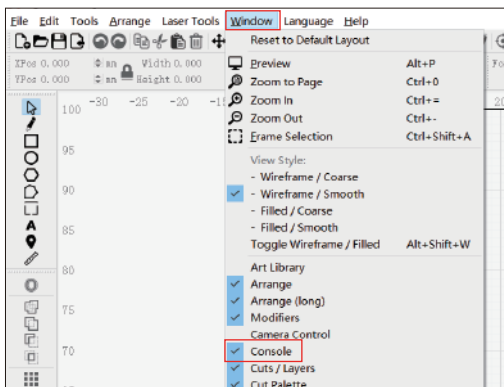

02. Select any custom button, right click mouse to pop up the button setting page, enter the name of the button in "Button Label", enter [ESP501] under "Macro contents"

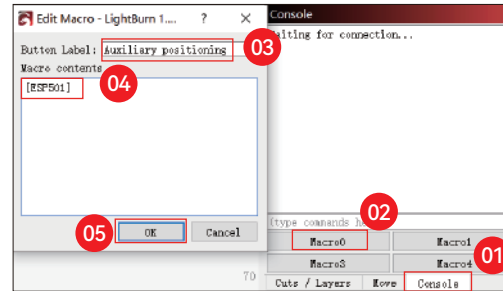

03. After clicking OK, a button with the corresponding function will be generated



(A.1) How to use "Auxiliary positioning" function in LightBurn:

01. Click "Set Origin"
02. Click "Frame"
03. Click "Auxiliary Positioning"
04. Click "Start"

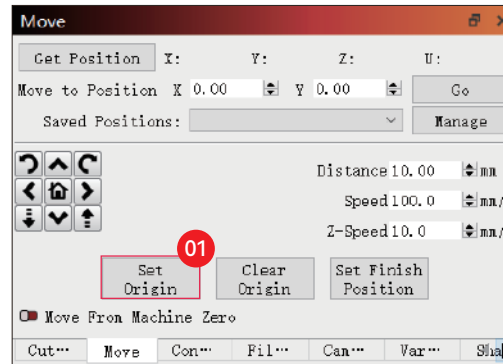

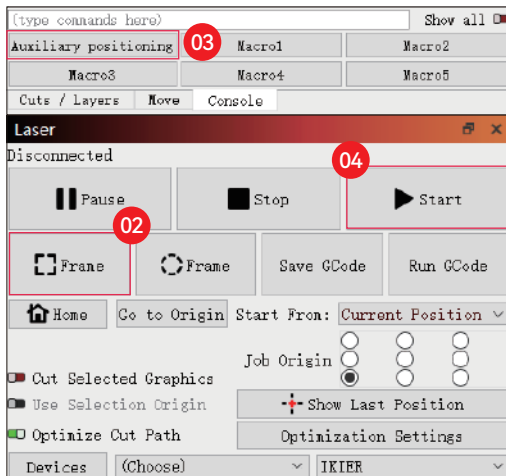

(B.1)How to use "Auxiliary positioning" function in LaserGRBL:

01. Click "Set Origin"
02. Click "Frame"
03. Click "Auxiliary Positioning"
04. Click "Start"

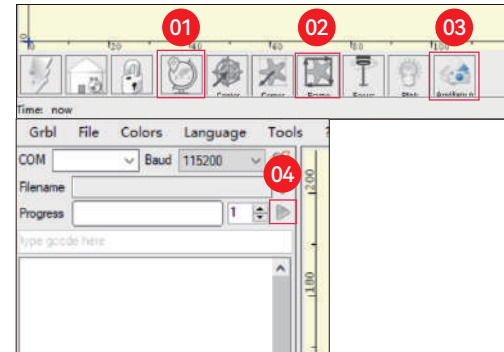

(B) How to set "Auxiliary positioning" function in LaserGRBL:

01. In the following toolbar, right click on the blank space to pop up the "Add Custom Button" window, click "Add Custom Button"

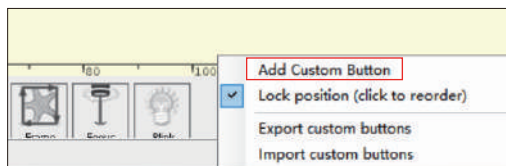

02. Enter [ESP501] in "GCode", enter the button name in "Caption" and "Tool Tip", you can customize the button picture on the left, and click "Create" to generate a custom button with the corresponding function

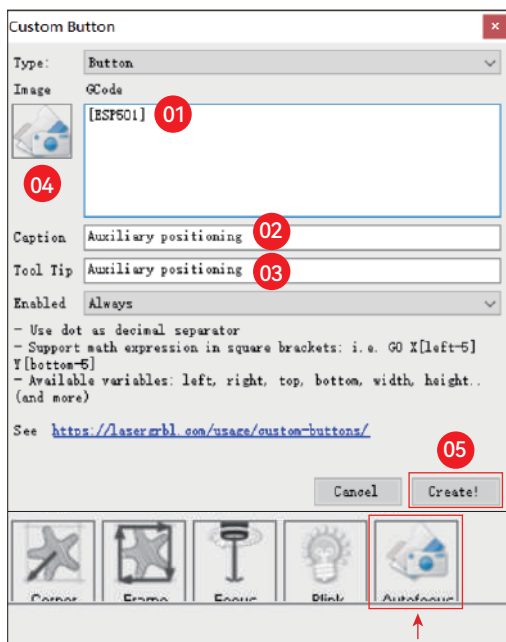

Sinking Cutting ▶

01. Open LightBurn, click "Device Settings", and enable Z-axis.

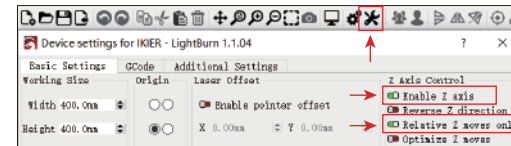

02. Set the number of passes and the Z-axis step size of each pass, and click OK.

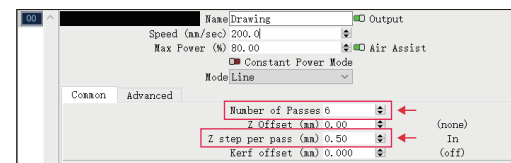

* WARNING:

01. The fixed focus distance of the laser module is 8mm, so "Number of Passes*Z step per pass<8mm", so as not to touch the lower limit switch and trigger alarm.

02. The focus must be fixed according to the standard 8mm height, and the focal length of the laser head cannot be lowered at the beginning, otherwise the flame detection function will be triggered by mistake.



Customer Service:

For detailed warranty policy, please visit our official website:

www.ikier.com, www.atomstack.net

For technical support and service, please email:

support@ikier.com, support@atomstack.net

Manufacturer:

Shenzhen Ikier Technologies Co., Ltd.

Address:

422, Building 1, Xili Bright Science Park, No. 178, Zhuguang
North Road, Nanshan District, Shenzhen, China

Scan QR code:

QR code reader/barcode scanner or any app with a scanner



You can download the mobile app
"IKIER" in major app stores



IKIER